

# Reliability Test Report

Product Name: Ai-WB2-01S

Product Model: WB2 Series

Test Date: 2022/12/05–2022/12/10

Tested by: Liu Qun

Reviewed by: Lu Xingui



## 1. Inspection Plan

No.	Process Name	Inspection Item	Inspection Equipment	Sampling Level (Refer to GB/T 2828.1-2012)	Acceptable Quality Level		
					CR (Critical Defect)	MA (Major Defect)	MI (Minor Defect)
1	Reliability test	High/low temperature storage; high/room/low temperature power on/off; high/low temperature operation; alternating hot and humid; thermal shock	Constant temperature and humidity chamber	Normal single sampling, special inspection S-1	0 accept, 1 reject		

## 2. Test Items

No.	Item	Test Conditions
1	Low temperature storage test	Test conditions: -40°C Test duration: 8hrs After an 8-hour soak at -40°C, perform a cold start test.
2	High temperature storage test	Test conditions: 100°C + 93% RH Test duration: 8h After restoring to 85°C and a 1-hour soak, perform a hot start test.
3	Low temperature operation test	Test conditions: -40°C Test duration: 24hrs
4	High temperature operation test	Test conditions: 85°C + 93% RH Test duration: 24hrs
5	AC power on/off test with temperature	A) Temperature: -40°C B) Temperature: 25°C + 93% RH C) Temperature: 85°C + 93% RH Cycle each condition 200 times, with 30s ON and 30s OFF
6	Alternating hot and humid test	A) Operate at 85°C + 93% RH for 4h; B) Operate at 25°C + 93% RH for 4h; Cycle steps A and B for a total of 2 cycles.
7	Thermal shock test	Test conditions: -40°C–100°C + 93% RH, soak for 30min at each temperature. Temperature transition time: 50min for heating, 2h for cooling. Test duration: 5 cycles

### 3. Test Preparation

No.	Item	Image/Attachment
1	Reliability documentation	Refer to the WB2 series reliability documentation
2	Test equipment	
3	Sample placement	
4	Test reason	<p>Verification pilot production using the Jinghua 113027008 SMD crystal (3225, 40MHz, 10ppm, 10pF, -30 to 85°C, taped) to replace the 13027006 SMD crystal (MDH, 3225, 40MHz, 10ppm, 10pF, -30 to 85°C) in the BOM</p>

### 4. Low Temperature Storage Test

**Test Conditions:** Power-off test. Store the product at -40°C for 8h, then perform a cold start test.

**Test Profile:**

Is Power Off ——  
Is Power On ——

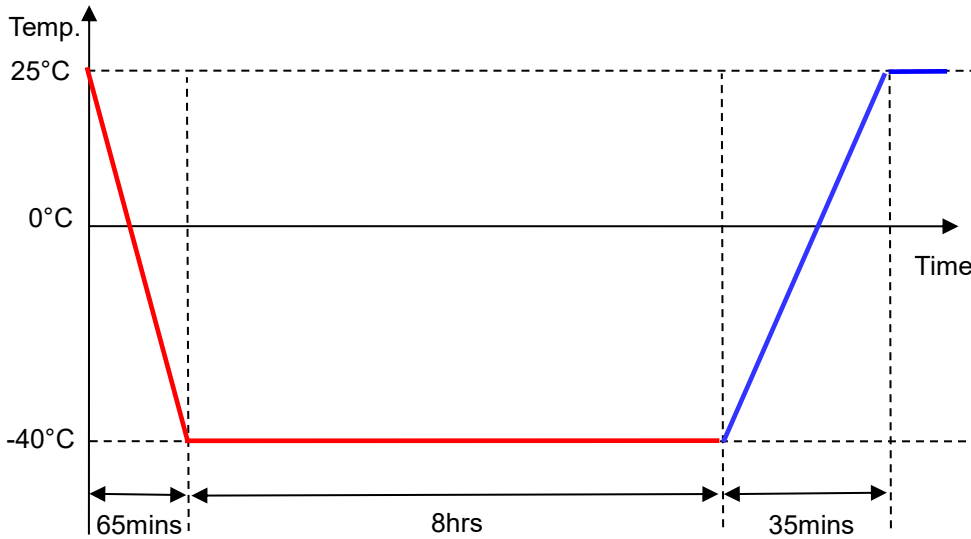

**Test Criteria:**

1. During the cold start test, the module functions normally. If ping packets are confirmed not to be lost, the module is considered to be functional.
2. After the test, the product shows no visible damage such as shrinkage, peeling, or discoloration.

Sample Quantity	Test Data	Test Results
3PCS		PASS

### 5. High Temperature Storage Test

**Test Conditions:** Power-off test. Store the product at 100°C + 93% RH for 8h, then restore it to 85°C + 93% RH for a 1-hour soak, and perform a hot start test.

**Test Profile:**

**Is Power Off**      —  
**Is Power On**      —

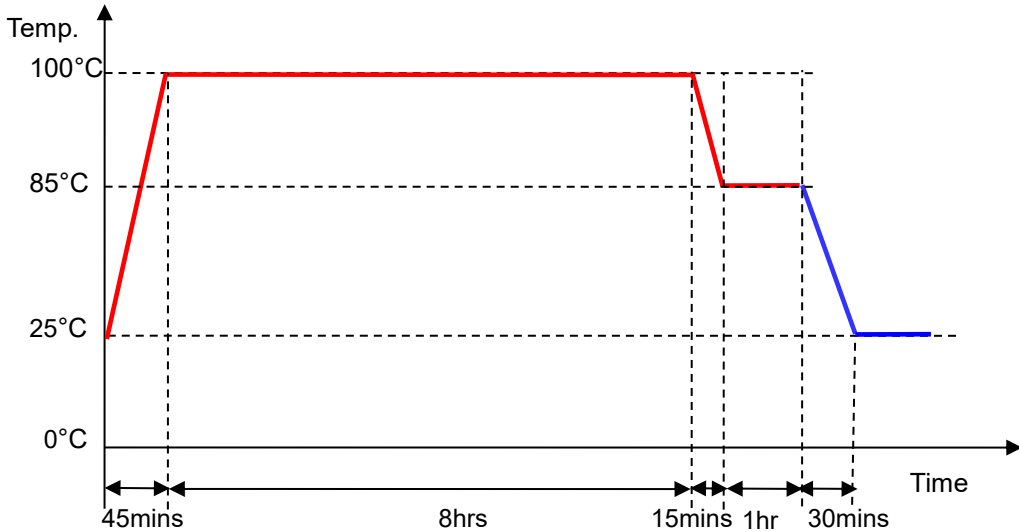

**Test Criteria:**

1. During the hot start test, the module functions normally. If ping packets are confirmed not to be lost, the module is considered to be functional.
2. After the test, the product shows no visible damage such as shrinkage, peeling, or discoloration.

Sample Quantity	Test Data	Test Results
3PCS		PASS

## 6. Low Temperature Operation Test

**Test Conditions:** Power-on test. Operate at -40°C for 24h.

**Test Profile:**

Is Power Off —  
Is Power On —

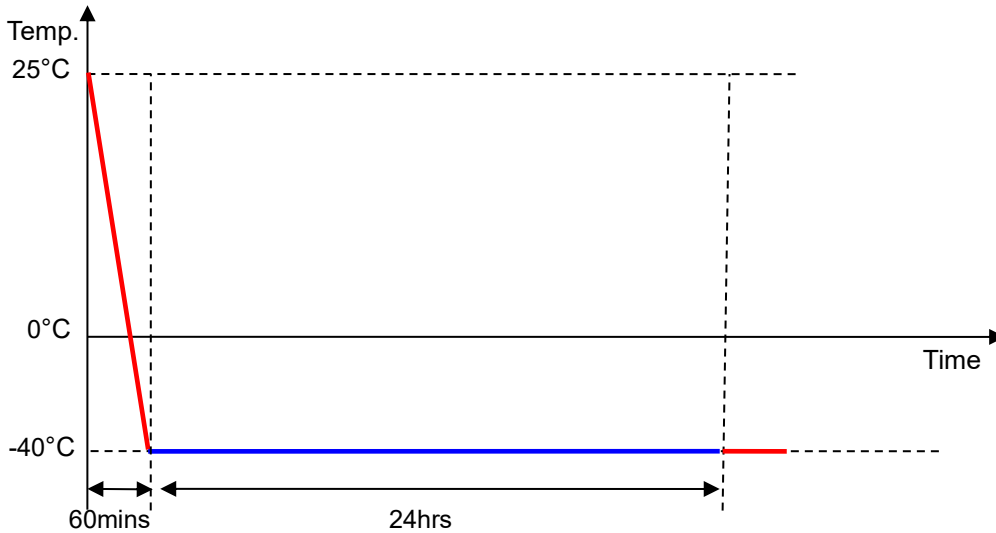

### Test Criteria:

1. No network disconnections occurred during the test. If ping packets are confirmed not to be lost, the module is considered to be functional.
2. After the test, the product shows no visible damage such as shrinkage, peeling, or discoloration.

Sample Quantity	Test Data	Test Results
3PCS	<p>The screenshots show the ATKXPING interface with the following statistics:</p> <ul style="list-style-type: none"> <li>Target 1 (192.168.3.5): 48 pings, 0% loss, 8.65ms avg.</li> <li>Target 2 (192.168.3.4): 113 pings, 0% loss, 8.93ms avg.</li> <li>Target 3 (192.168.3.3): 74 pings, 0% loss, 7.53ms avg.</li> </ul>	PASS

## 7. High Temperature Operation Test

**Test Conditions:** Operate at 85°C+ 93% RH for 24h.

**Test Profile:**

**Is Power Off** ——  
**Is Power On** ——

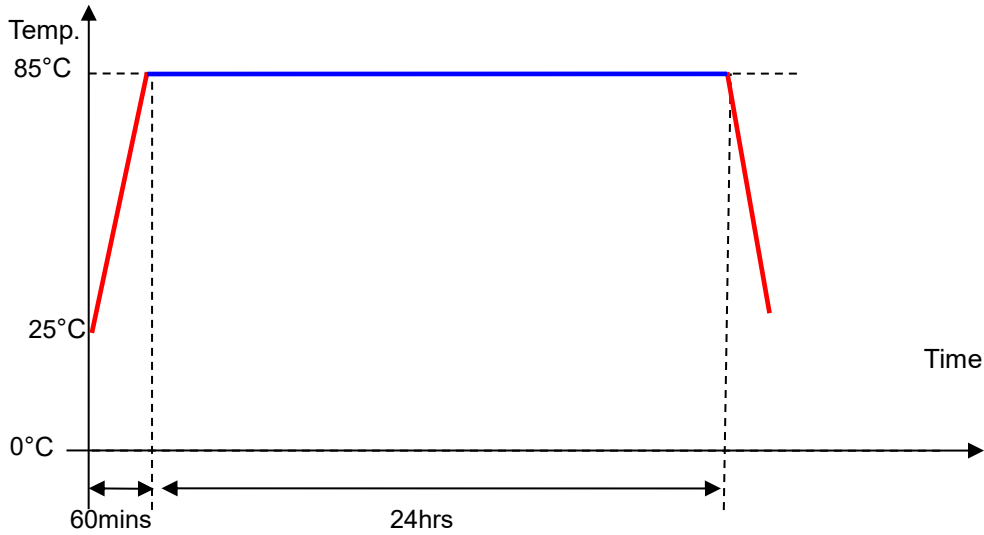

**Test Criteria:**

1. No network disconnections occurred during the test. If ping packets are confirmed not to be lost, the module is considered to be functional.
2. After the test, the product shows no visible damage such as shrinkage, peeling, or discoloration.

Sample Quantity	Test Data	Test Results
3PCS	<p>The test data consists of three screenshots of the ATKXPING software interface. Each screenshot shows a successful ping test to a target IP address (192.168.3.5, 192.168.3.4, and 192.168.3.3). The 'Ping 统计信息' (Ping Statistics) section in each screenshot shows 100% success rate, 0.00% packet loss, and various response times (min, max, average) and TTL values.</p>	PASS

## 8. AC Power On/Off Test with Temperature

- Test Conditions:**
- Power on: 30s; power off: 30s.
  - Temperature: -40°C, 25°C + 93% RH, 85°C + 93% RH.
  - Cycle: Each test condition cycles 200 times.

**Test Profile:**

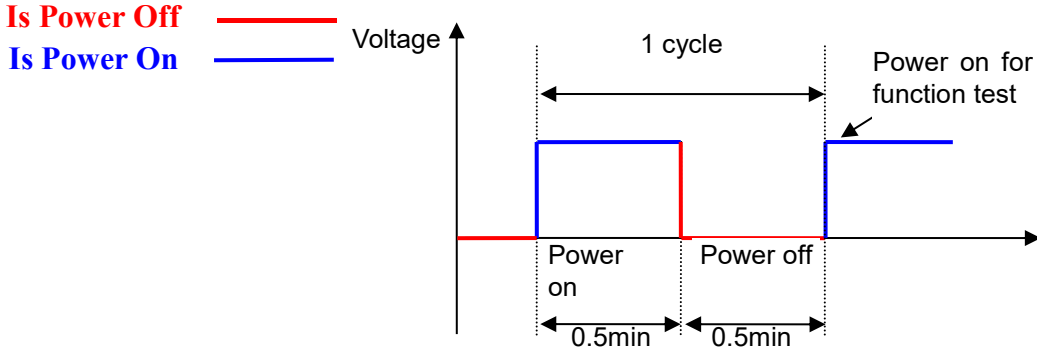

**Test Criteria:**

- After power-up, the module boots normally. During the test, if the module boots normally and there is connectivity for every ping packet, the module is considered to be functional.
- After the test, the product shows no visible damage such as shrinkage, peeling, or discoloration.

Item	Sample Quantity	Test Data	Test Results
Power on/off at room temperature	3PCS		PASS
Power on/off at low temperature	3PCS		PASS
Power on/off at high temperature	3PCS		PASS

## 9. Alternating Hot and Humid Test

### Test Conditions:

1. Operate at 85°C + 93% RH for 4h;
  2. Operate at 25°C + 93% RH for 4h;
- Cycle step 1 and step 2, a total of 2 cycles.

### Test Profile:

Is Power Off —  
Is Power On —

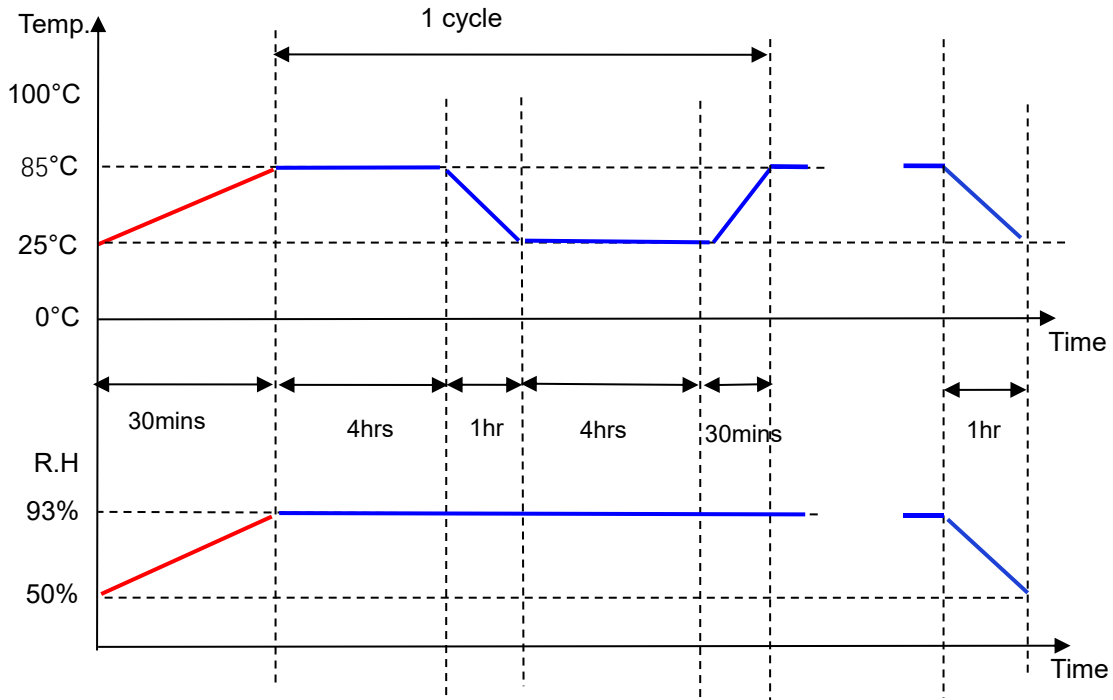

### Test Criteria:

1. No network disconnections occurred during the test. If ping packets are confirmed not to be lost, the module is considered to be functional.
2. After the test, the product shows no visible damage such as shrinkage, peeling, or discoloration.

Sample Quantity	Test Data	Test Results
3PCS		PASS

## 10. Thermal Shock Test

### Test Conditions:

Power-off test. Temperature cycling between -40–100°C + 93% RH, with a heating time of 50min and a cooling time of 2h. Each stage is held for 30min, for a total of 5 cycles.

### Test Profile:

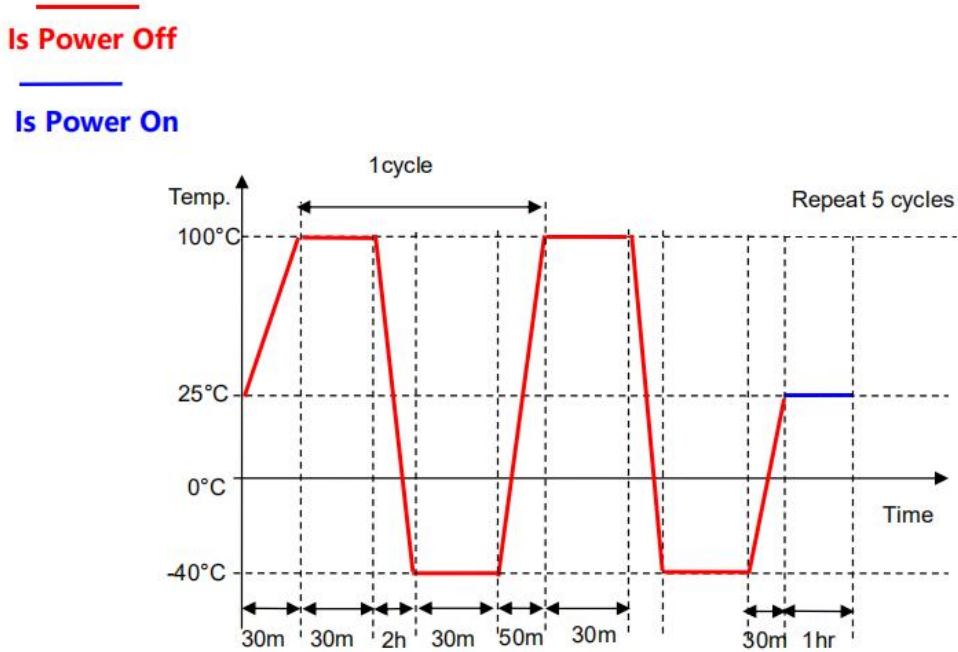

### Test Criteria:

1. After power-up, the module boots normally. If ping packets are confirmed not to be lost, the module is considered to be functional.
2. After the test, the product shows no visible damage such as shrinkage, peeling, or discoloration.

Sample Quantity	Test Data	Test Results
3PCS		PASS