

Reliability Test Report

Product Name: Ai-WB2-07S

Product Model: WB2 Series

Test Date: 2022/07/07–2022/07/12

Tested by: Liu Qun

Reviewed by: Lu Xingui

1. Inspection Plan

No.	Process Name	Inspection Item	Inspection Equipment	Sampling Level (Refer to GB/T 2828.1-2012)	Acceptable Quality Level		
					CR (Critical Defect)	MA (Major Defect)	MI (Minor Defect)
1	Reliability test	High/low temperature storage; high/room/low temperature power on/off; high/low temperature operation; alternating hot and humid; thermal shock	Constant temperature and humidity chamber	Normal single sampling, special inspection S-1	0 accept, 1 reject		

2. Test Items

No.	Item	Test Conditions
1	Low temperature storage test	Test conditions: -40°C Test duration: 8h After an 8-hour soak at -40°C, perform a cold start test.
2	High temperature storage test	Test conditions: 100°C Test duration: 8h After restoring to 85°C and a 1-hour soak, perform a hot start test.
3	Low temperature operation test	Test conditions: -40°C Test duration: 24h
4	High temperature operation test	Test conditions: 85°C Test duration: 24h
5	AC power on/off test with temperature	A) Temperature: -40°C B) Temperature: 25°C C) Temperature: 85°C Cycle each condition 200 times, with 30s ON and 30s OFF
6	Alternating hot and humid test	A) Operate at 85°C + 93% RH for 4h; B) Operate at 25°C + 93% RH for 4h; Cycle steps A and B for a total of 2 cycles.
7	Thermal shock test	Test conditions: -40°C–100°C, soak for 30min at each temperature. Temperature transition time: 50min for heating, 2h for cooling. Test duration: 5 cycles

3. Test Preparation

No.	Item	Image/Attachment
1	Reliability documentation	 WB2系列模组 可靠性WIFI&蓝牙
2	Test equipment	
3	Sample placement	
4	Test reason	New product

4. Low Temperature Storage Test

Test Conditions: Power-off test. Store the product at -40°C for 8h, then perform a cold start test.

Test Profile:

Is Power Off ——
Is Power On ——

Test Criteria:

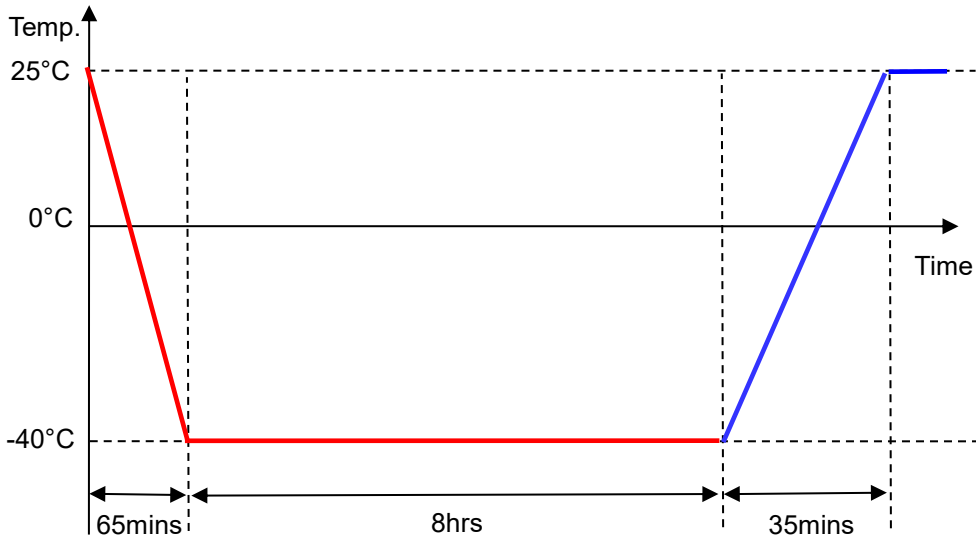

1. During the cold start test, the module functions normally. If ping packets are confirmed not to be lost, the module is considered to be functional.
2. Test the Bluetooth functionality. Send the command AT+BLEINIT=2 to enable Bluetooth and configure the Bluetooth application name. Then open the BLE debugging assistant to search for the Bluetooth name (e.g., BL-AT7/8/9/10/11/12). If the name is not found, the test is considered to be failed.
3. After the test, the product shows no visible damage such as shrinkage, peeling, or discoloration.

Sample Quantity	Test Data	Test Results
<p>6PCS (BL-AT7-BL-AT12)</p>	<p>The test data section contains two main parts. The top part shows six screenshots of the AT+PING software interface, each displaying test parameters like 'Ping 次数: 1000', 'Ping 成功率: 100%', and 'Ping 平均延迟: 0.00ms'. The bottom part shows a screenshot of a mobile application titled 'BLE调试助手' (BLE Debugging Assistant) in 'Scanner' mode. It lists several Bluetooth devices, including BL-AT7, BL-AT11, BL-AT10, BL-AT12, BL-AT9, BL-AT5, BL-AT6, and BL-AT8, along with their MAC addresses and signal strengths (e.g., -61 dBm, -60 dBm, etc.).</p>	<p>PASS</p>

5. High Temperature Storage Test

Test Conditions: Power-off test. Store the product at 100°C for 8h, then restore it to 85°C for a 1-hour soak, and perform a hot start test.

Test Profile:

Is Power Off —
Is Power On —

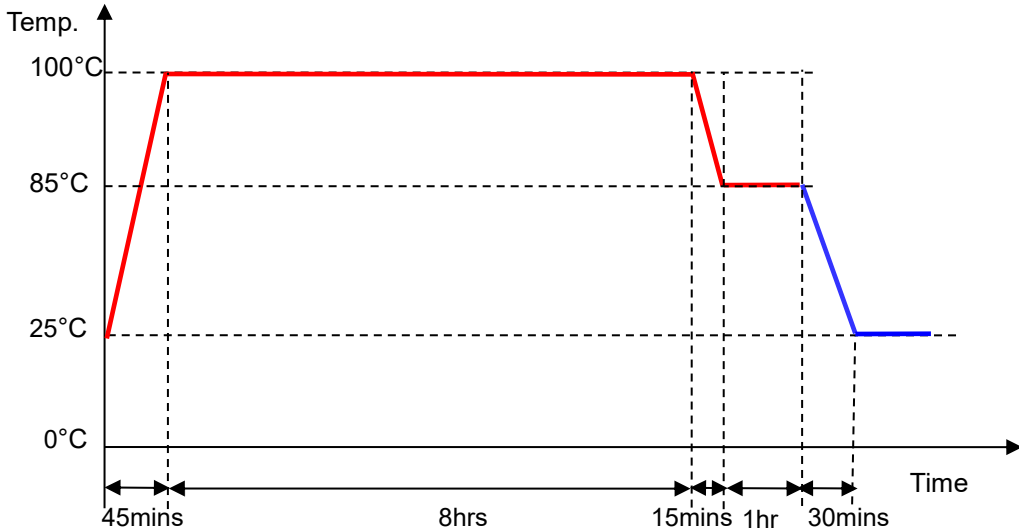

Test Criteria:

1. During the hot start test, the module functions normally. If ping packets are confirmed not to be lost, the module is considered to be functional.
2. Test the Bluetooth functionality. Send the command AT+BLEINIT=2 to enable Bluetooth and configure the Bluetooth application name. Then open the BLE debugging assistant to search for the Bluetooth name (e.g., BL-AT7/8/9/10/11/12). If the name is not found, the test is considered to be failed.
3. After the test, the product shows no visible damage such as shrinkage, peeling, or discoloration.

Sample Quantity	Test Data	Test Results
<p>6PCS (BL-AT7-BL-AT12)</p>	<p>The test data section contains two screenshots. The top screenshot shows six instances of the ATKEPPING software, each displaying ping test results for a specific module (BL-AT7 to BL-AT12). The results show successful ping counts and no packet loss. The bottom screenshot shows a BLE debugging assistant interface with a list of discovered Bluetooth devices, including BL-AT7 through BL-AT12, each with a 'CONNECT' button.</p>	<p>PASS</p>

6. Low Temperature Operation Test

Test Conditions: Power-on test. Operate at -40°C for 24h.

Test Profile:

Is Power Off —
Is Power On —

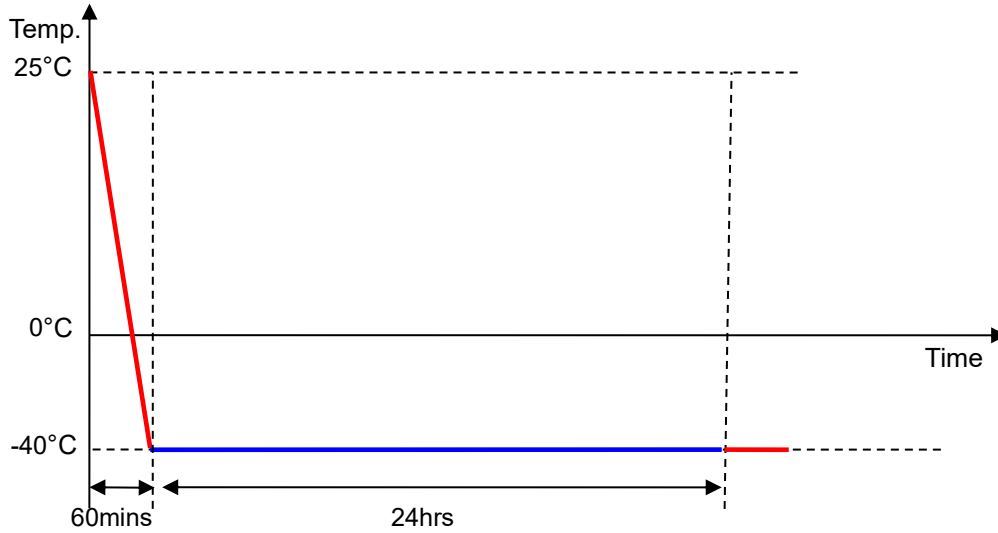

Test Criteria:

1. No network disconnections occurred during the test. If ping packets are confirmed not to be lost, the module is considered to be functional.
2. During the test, open the BLE debugging assistant to search for the Bluetooth name (e.g., BL-AT7/8/9/10/11/12). If the name is not found, the test is considered to be failed.
3. After the test, the product shows no visible damage such as shrinkage, peeling, or discoloration.

Sample Quantity	Test Data	Test Results
<p>6PCS (BL-AT7- BL-AT12)</p>	<p>The test data section contains screenshots of ATKOPING ping test results for multiple samples, showing successful ping operations with 0.00% packet loss. Below this is a screenshot of the BLE debugging assistant interface, which lists several discovered Bluetooth devices including BL-AT10, BL-AT8, BL-AT11, BL-AT12, BL-AT9, and BL-AT7, all with their respective MAC addresses and signal strengths.</p>	<p>PASS</p>

7. High Temperature Operation Test

Test Conditions: Operate at 85°C for 24h.

Test Profile:

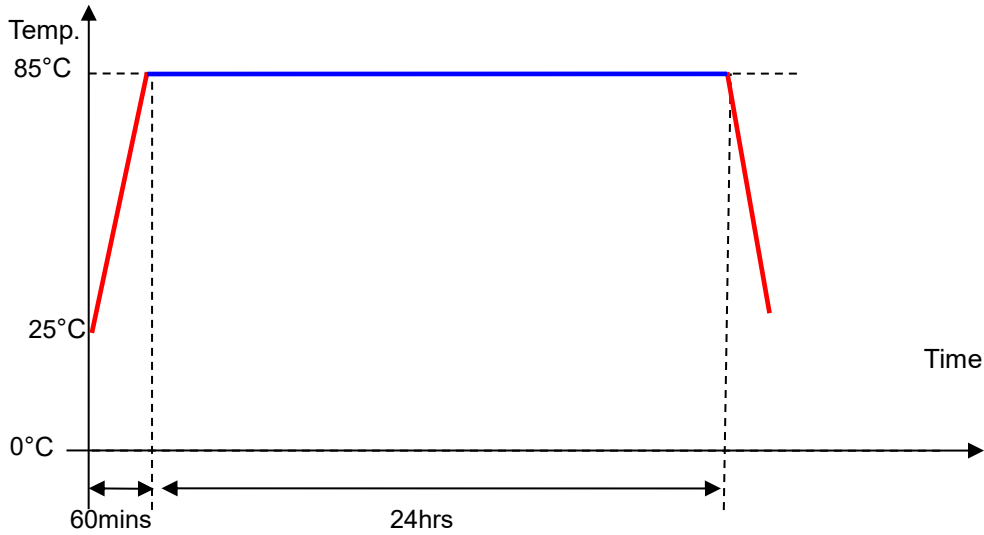

Test Criteria:

1. No network disconnections occurred during the test. If ping packets are confirmed not to be lost, the module is considered to be functional.
2. During the test, open the BLE debugging assistant to search for the Bluetooth name (e.g., BL-AT7/8/9/10/11/12). If the name is not found, the test is considered to be failed.
3. After the test, the product shows no visible damage such as shrinkage, peeling, or discoloration.

Sample Quantity	Test Data	Test Results
<p>6PCS (BL-AT7-BL-AT12)</p>		<p>PASS</p>

8. AC Power On/Off Test with Temperature

- Test Conditions:**
1. Power on: 30s; power off: 30s.
 2. Temperature: -40°C, 25°C, 85°C.
 3. Cycle: Each test condition cycles 200 times.

Test Profile:

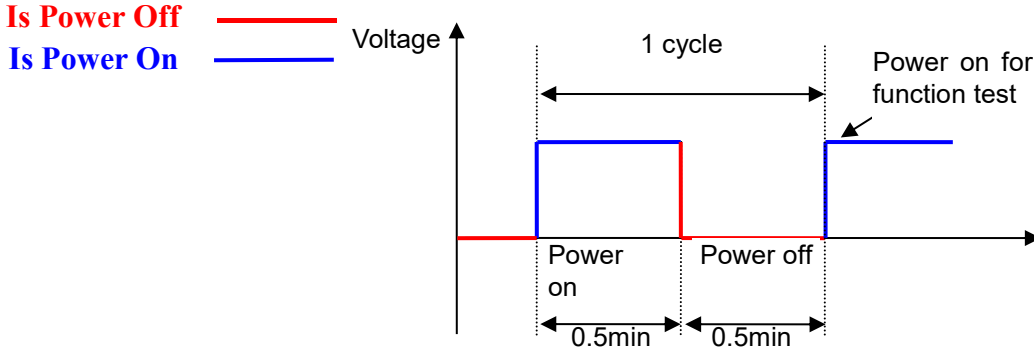

Test Criteria:

1. After power-up, the module boots normally. During the test, if the module boots normally and there is connectivity for every ping packet, the module is considered to be functional.
2. Test the Bluetooth functionality. Send the command AT+BLEINIT=2 to enable Bluetooth and configure the Bluetooth application name. Then open the BLE debugging assistant to search for the Bluetooth name (e.g., BL-AT7/8/9/10/11/12). If the name is not found, the test is considered to be failed.
3. After the test, the product shows no visible damage such as shrinkage, peeling, or discoloration.

Item	Sample Quantity	Test Data	Test Results
Power on/off at room temperature	6PCS (BL-AT7–BL-AT12)		PASS

Power on/off at low temperature

6PCS
(BL-AT7-BL-AT12)

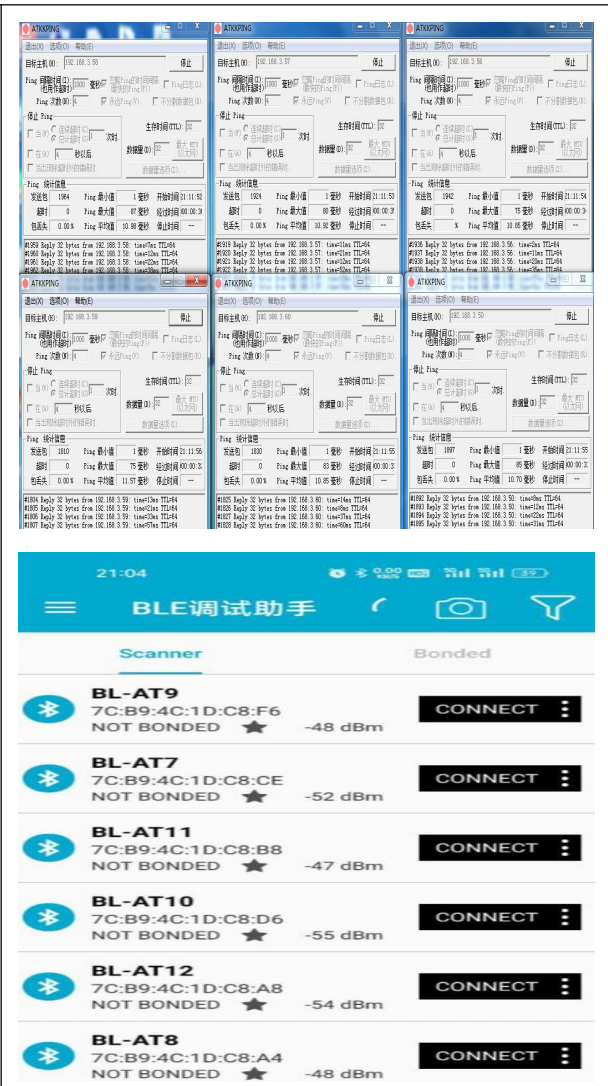

PASS

Power on/off at high temperature

6PCS
(BL-AT7-BL-AT12)

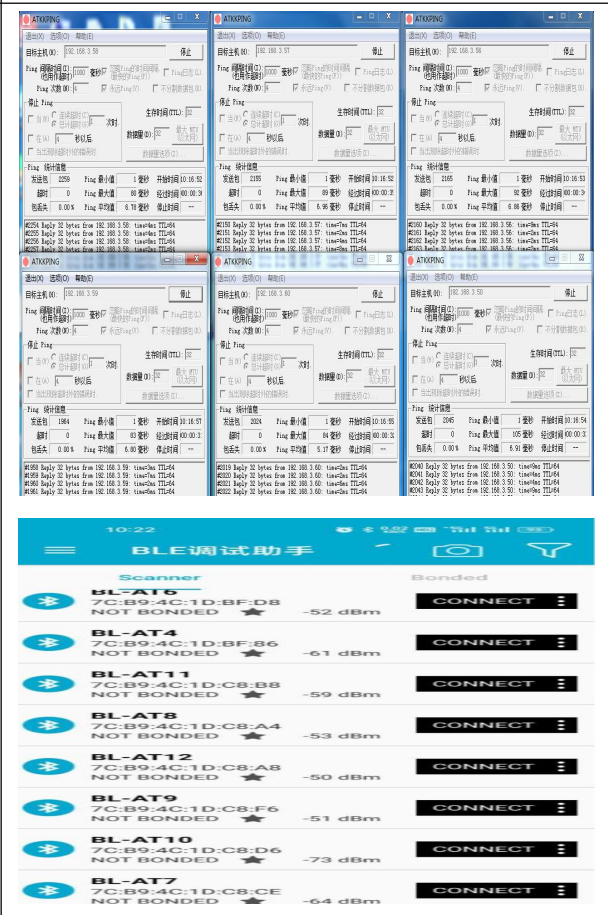

PASS

9. Alternating Hot and Humid Test

Test Conditions:

1. Operate at 85°C + 93% RH for 4h;
 2. Operate at 25°C + 93% RH for 4h;
- Cycle step 1 and step 2, a total of 2 cycles.

Test Profile:

Is Power Off ——— (Red line)
Is Power On ——— (Blue line)

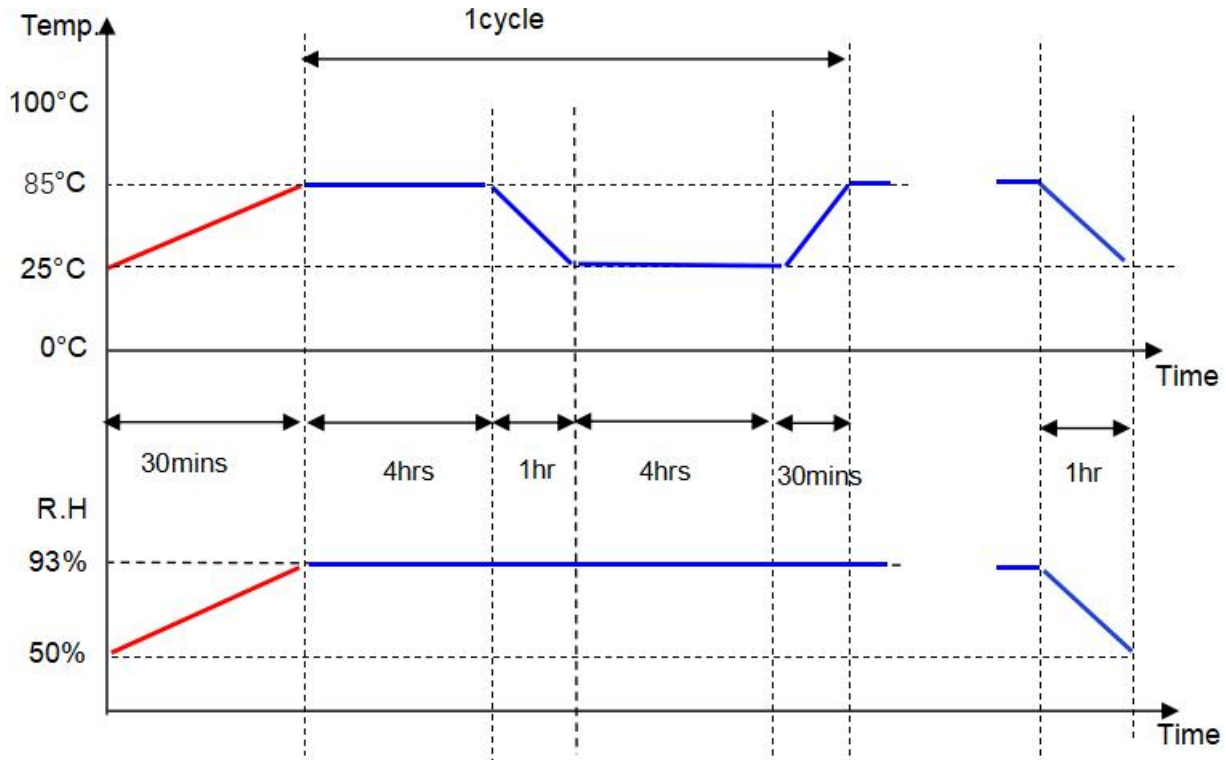

Test Criteria:

1. If the module operates normally and no ping packet loss is confirmed, the module is considered to be functional.
2. During the test, open the BLE debugging assistant to search for the Bluetooth name (e.g., BL-AT7/8/9/10/11/12). If the name is not found, the test is considered to be failed.
3. After the test, the product shows no visible damage such as shrinkage, peeling, or discoloration.

Sample Quantity	Test Data	Test Results
<p>6PCS (BL-AT7–BL-AT12)</p>		<p>PASS</p>

10. Thermal Shock Test

Test Conditions:

Power-off test. Temperature cycling between -40–100°C, with a heating time of 50min and a cooling time of 2h. Each stage is held for 30min, for a total of 5 cycles.

Test Profile:

Is Power Off
Is Power On

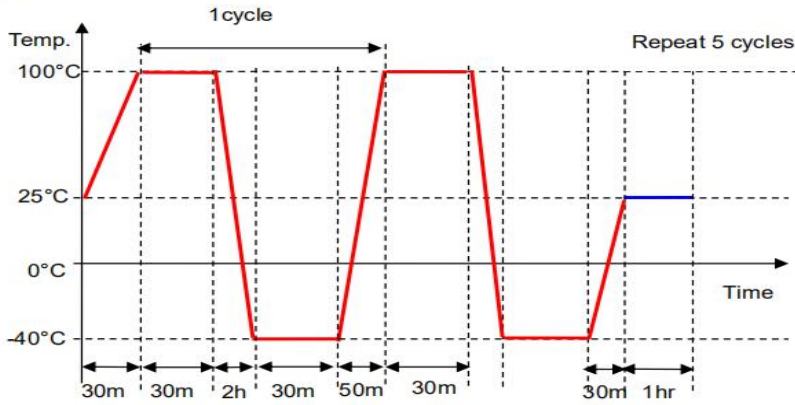

Test Criteria:

1. After power-up, the module boots normally. During the test, if the module boots normally and ping packets are confirmed not to be lost, the module is considered to be functional.
2. During the test, open the BLE debugging assistant to search for the Bluetooth name (e.g., BL-AT7/8/9/10/11/12). If the name is not found, the test is considered to be failed.
3. After the test, the product shows no visible damage such as shrinkage, peeling, or discoloration.

Sample Quantity	Test Data	Test Results
<p>6PCS (BL-AT7–BL-AT12)</p>		<p>PASS</p>