

Reliability Test Report

Product Name: EC-01

Product Model: NB-LoT Series

Test Date: 2021/09/09–2021/09/13

Tested by: Lu Xingui

Reviewed by: Zhou Yuming

1. Inspection Plan

No.	Process Name	Inspection Item	Inspection Equipment	Sampling Level (Refer to GB/T 2828.1-2012)	Acceptable Quality Level		
					CR (Critical Defect)	MA (Major Defect)	MI (Minor Defect)
1	Reliability test	High/low temperature storage; high/room/low temperature power on/off; high/low temperature operation	Constant temperature and humidity chamber	Normal single sampling, special inspection S-1	0 accept, 1 reject		

2. Test Items

No.	Item	Test Conditions
1	Low temperature storage test	Test conditions: -40°C Test duration: 8h After restoring to -25°C and a 1-hour soak, perform a cold start test.
2	High temperature storage test	Test conditions: 100°C Test duration: 8h After restoring to 85°C and a 1-hour soak, perform a hot start test.
3	Low temperature operation test	Test conditions: -20°C Test duration: 24h
4	High temperature operation test	Test conditions: 85°C Test duration: 24h
5	AC power on/off test with temperature	A) Temperature: -20°C B) Temperature: 25°C C) Temperature: 85°C Cycle each condition 200 times, with 30s ON and 30s OFF.

3. Test Preparation

No.	Item	Image/Attachment
1	Reliability documentation	 EC-01&EC-01G &EC-01F可靠性测

<p>2</p>	<p>Test equipment</p>	
<p>3</p>	<p>Sample placement</p>	

4. Low Temperature Storage Test

Test Conditions: Power-off test. Store the product at -40°C for 8h, then restore it to -25°C for a 1-hour soak, and perform a cold start test.

Test Profile:

Is Power Off ——— (Red line)
Is Power On ——— (Blue line)

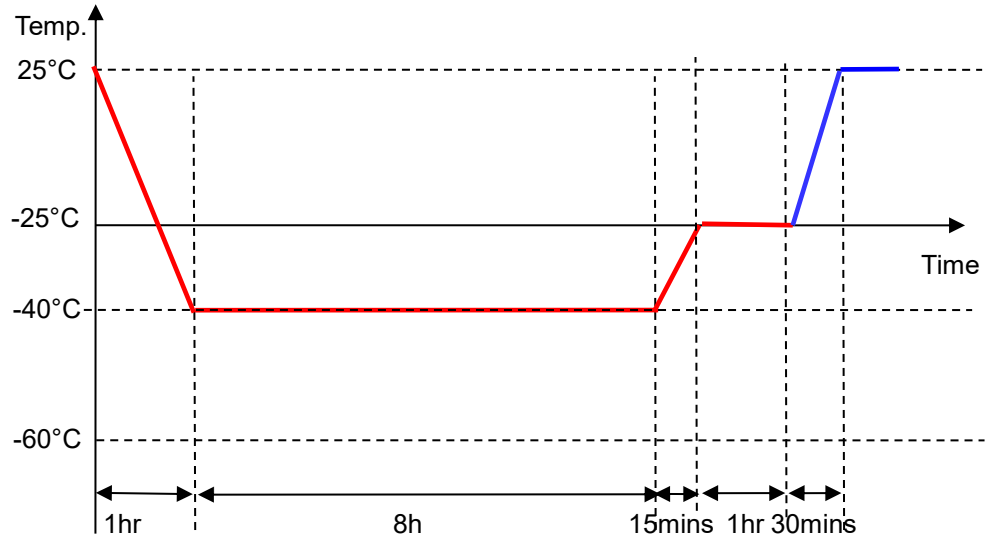

6. Low Temperature Operation Test

Test Conditions: Power-on test. Operate at -40°C for 24h.

Test Profile:

Is Power Off ————
Is Power On ————

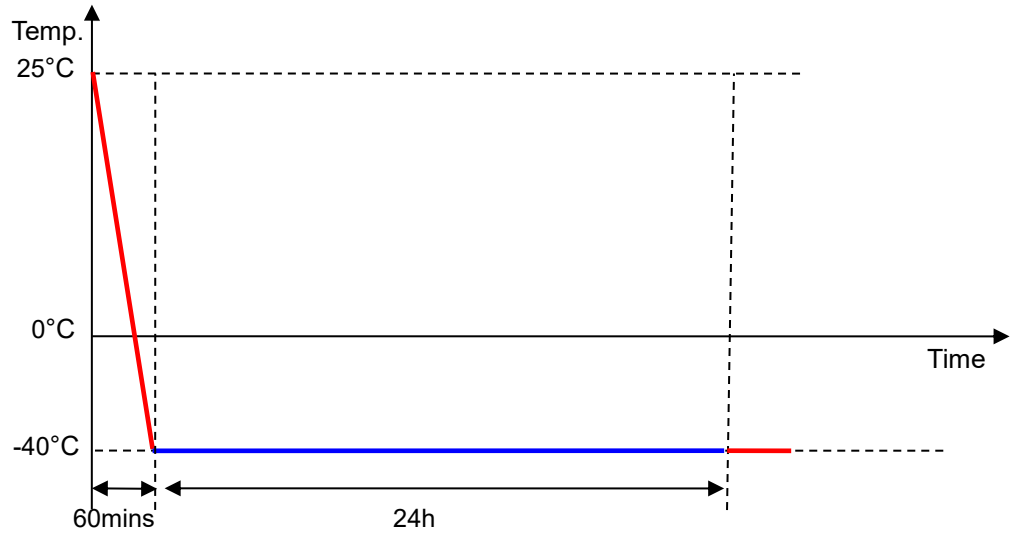

Test Criteria:

1. No network disconnections occurred during the test. If the module does not crash after operating at low temperature for 24h, it is considered PASS. (To determine if it has crashed, input the AT command directly via the serial port and check if the board has any print output.) Thus, the module function is considered to be normal.

2. After the test, the product shows no visible damage such as shrinkage, peeling, or discoloration.

Sample Quantity	Test Data	Test Results
Unit 1 Unit 2		PASS

7. High Temperature Operation Test

Test Conditions: Operate at 85°C for 24h.

Test Profile:

Is Power Off ————
Is Power On ————

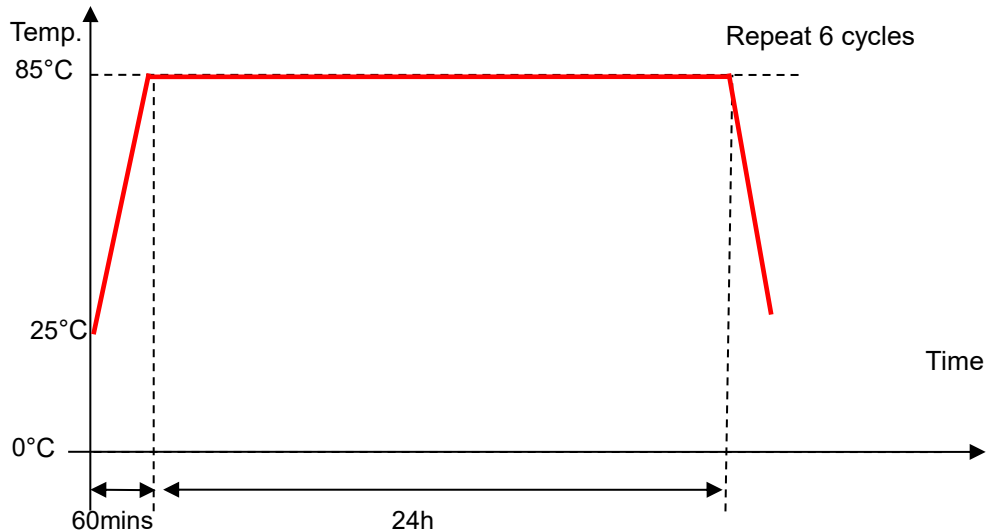

Test Criteria:

1. No network disconnections occurred during the test. If the module does not crash after operating at high temperature for 24h, it is considered PASS. (To determine if it has crashed, input the AT command directly via the serial port and check if the board has any print output.) Thus, the module function is considered to be normal.
2. After the test, the product shows no visible damage such as shrinkage, peeling, or discoloration.

Sample Quantity	Test Data	Test Results
Unit 1 Unit 2		PASS

8. AC Power On/Off Test with Temperature

- Test Conditions:**
1. Power on: 30s; power off: 30s.
 2. Temperature: -20°C, 25°C, 85°C.
 3. Cycle: Each test condition cycles 200 times.

Test Profile:

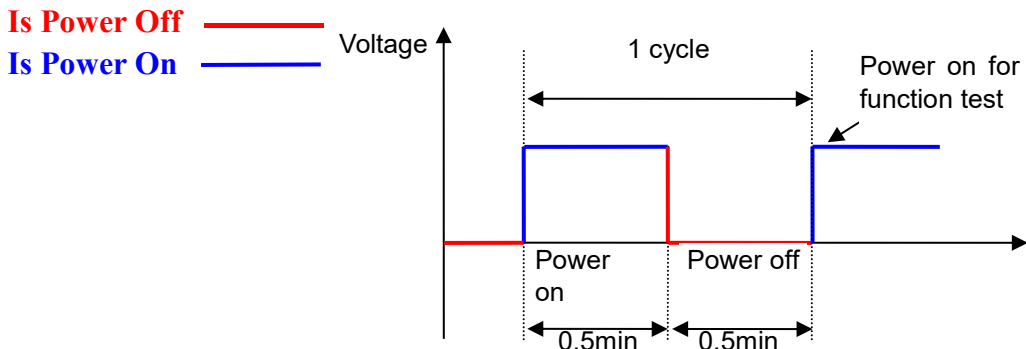

Test Criteria:

1. Place the module in room/high/low temperature for 60min respectively. Then the module undergoes continuous power cycling (50 cycles at high temperature and 50 cycles at low temperature). If the unit under test can start up and boot normally, it is considered PASS. Thus, the module function is considered to be normal.
2. After the test, the product shows no visible damage such as shrinkage, peeling, or discoloration.

Item	Sample Quantity	Test Data	Test Results
Power on/off at room temperature	Unit 1 Unit 2		PASS

Item	Sample Quantity	Test Data	Test Results
Power on/off at low temperature	Unit 1 Unit 2		PASS
Power on/off at high temperature	Unit 1 Unit 2		PASS