

Reliability Test Report

Product Name:	Radar Series
Product Model:	Rd-03H_V1.0
Test Date:	2025.05.19-2025.05.27
Tested by:	Dong Wenchao
Reviewed by:	An Sanchao

1. Inspection Standard

No.	Process Name	Inspection Item	Inspection Equipment	Sampling Level (Refer to GB/T 2828.1-2012)	Acceptable Quality Level		
					CR (Critical Defect)	MA (Major Defect)	MI (Minor Defect)
1	Reliability test	High/low temperature storage; high/room/low temperature power on/off; high/low temperature operation; alternating hot and humid; thermal shock	Constant temperature and humidity chamber	Normal single sampling, special inspection S-1	0 accept, 1 reject		

2. Test Items

No.	Item	Test Conditions
1	Low temperature storage test	Test conditions: -40°C Test duration: 8h After a 1-hour soak at -40°C, perform a cold start test.
2	High temperature storage test	Test conditions: 100°C + 93% RH Test duration: 8h After restoring to 85°C and a 1-hour soak, perform a hot start test.
3	Low temperature operation test	Test conditions: -40°C Test duration: 24h
4	High temperature operation test	Test conditions: 85°C + 93% RH Test duration: 24h
5	AC power on/off test with temperature	A) Temperature: -40°C B) Temperature: 25°C + 93% RH C) Temperature: 85°C + 93% RH Cycle each condition 200 times, with 30s ON and 30s OFF
6	Alternating hot and humid test	A) Operate at 85°C + 93% RH for 4h; B) Operate at 25°C + 93% RH for 4h; Cycle steps A and B for a total of 2 cycles.
7	Thermal shock test	Test conditions: -40°C–100°C + 93% RH, soak for 30min at each temperature Temperature transition time: 50min for heating, 2h for cooling. Test duration: 5 cycles

3. Test Preparation

No.	Item	Image/Attachment
1	Reliability documentation	 Rd-03H_V1.0可靠性测试说明20250519.doc
2	Test equipment	
3	Sample placement	
4	Test reason	New product reliability test (96010065)

4. Low Temperature Storage Test

Test Conditions: Power-off test. Store the product at -40°C for 8h, then perform a cold start test.

Test Profile:

Is Power Off ———

Is Power On ———

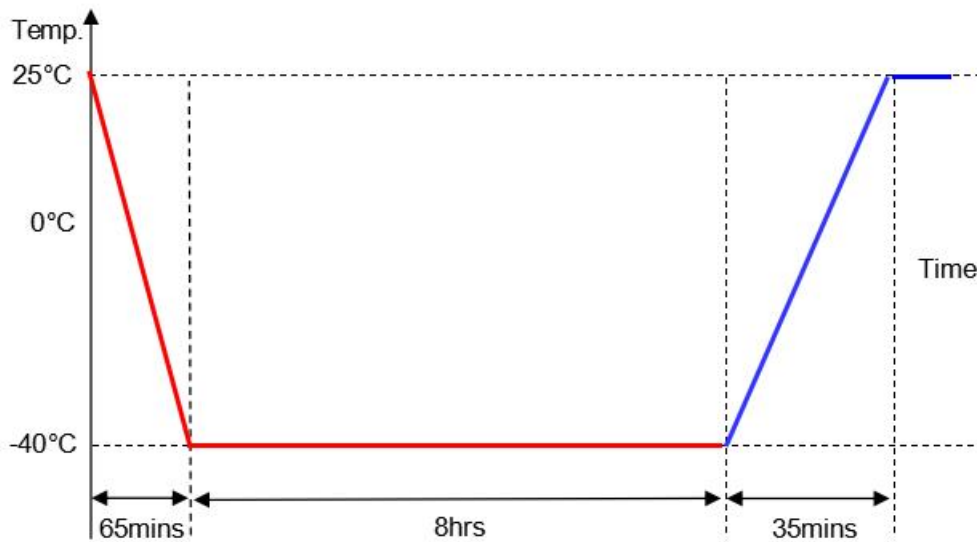

Test Criteria:

1. During the cold start test, the module functions normally. The waveforms and distance on the interface are changing, indicating the radar is working properly. Therefore, the module function is considered to be functional.
2. After the test, the product shows no visible damage such as shrinkage, peeling, or discoloration.

Sample Quantity	Test Data	Test Results
6PCS		PASS

5. High Temperature Storage Test

Test Conditions: Power-off test. Store the product at 100°C + 93% RH for 8h, then restore it to 85°C + 93% RH for a 1-hour soak, and perform a hot start test.

Test Profile:

Is Power Off ——— (Red line)
Is Power On ——— (Blue line)

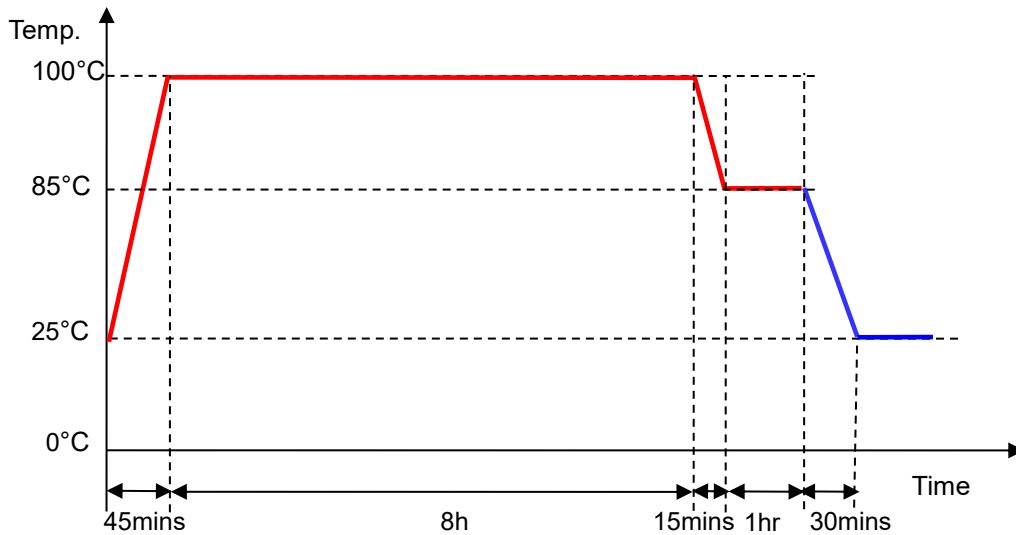

Test Criteria:

1. During the hot start test, the module functions normally. The waveforms and distance on the interface are changing, indicating the radar is working properly. Therefore, the module function is considered to be functional.
2. After the test, the product shows no visible damage such as shrinkage, peeling, or discoloration.

Sample Quantity	Test Data	Test Results
6PCS		PASS

6. Low Temperature Operation Test

Test Conditions: Power-on test. Operate at -40°C for 24h.

Test Profile:

Is Power Off ——

Is Power On ——

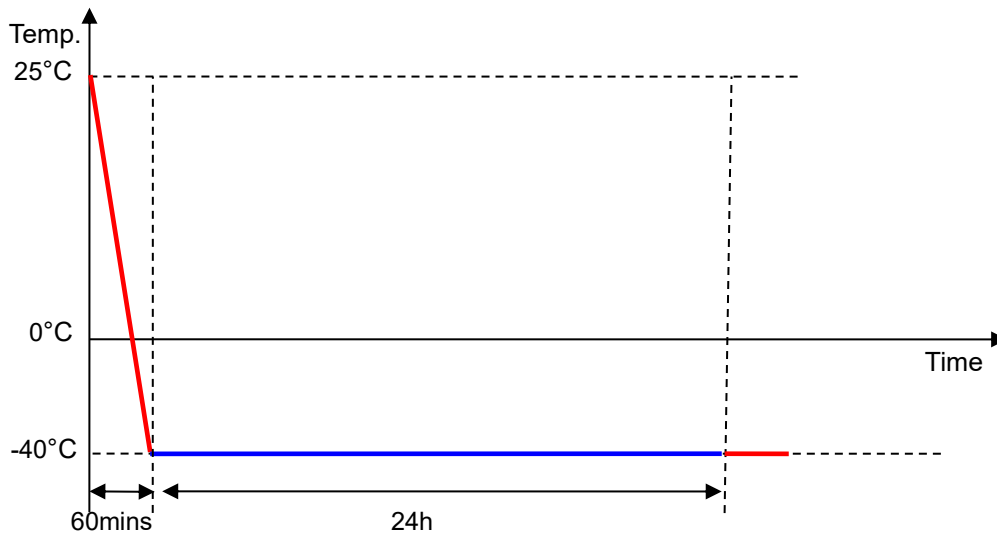

Test Criteria:

1. After connecting the module, the waveforms and distance on the interface are changing, thus the module function is considered to be functional.
2. After the test, the product shows no visible damage such as shrinkage, peeling, or discoloration.

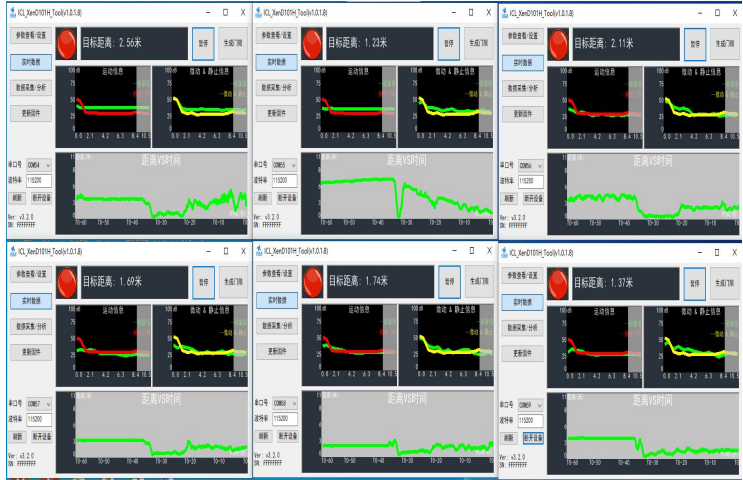
Sample Quantity	Test Data	Test Results
6PCS		PASS

7. High Temperature Operation Test

Test Conditions: Power-on test. Operate at 85°C+ 93% RH for 24h.

Test Profile:

Is Power Off ——
 Is Power On ——

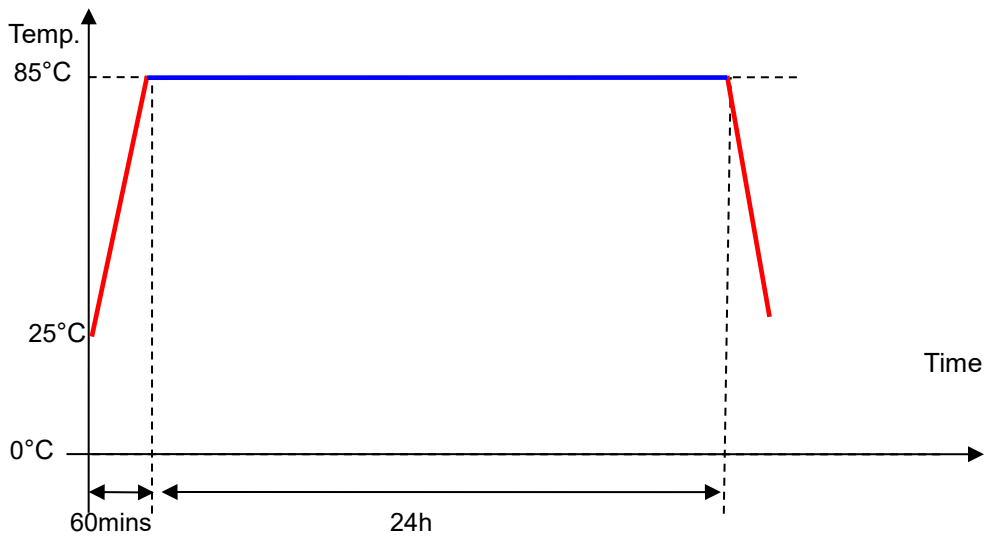

Test Criteria:

1. After connecting the module, the waveforms and distance on the interface are changing, indicating the radar is working properly. Therefore, the module function is considered to be functional.
2. After the test, the product shows no visible damage such as shrinkage, peeling, or discoloration.

Sample Quantity	Test Data	Test Results
6PCS		PASS

8. AC Power On/Off Test with Temperature

- Test Conditions:**
1. Power on: 30s; power off: 30s.
 2. Temperature: -40°C, 25°C + 93% RH, 85°C + 93% RH.
 3. Cycle: Each test condition cycles 200 times.

Test Profile:

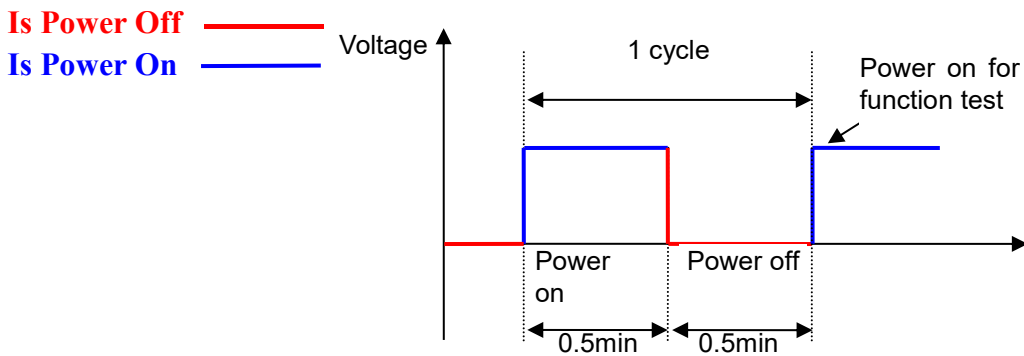

Test Criteria:

1. After connecting the module, the waveforms and distance on the interface are changing, indicating the radar is working properly. Therefore, the module function is considered to be functional.
2. After the test, the product shows no visible damage such as shrinkage, peeling, or discoloration.

Item	Sample Quantity	Test Data	Test Results
Power on/off at room temperature	6PCS		PASS
Power on/off at low temperature	6PCS		PASS
Power on/off at high temperature	6PCS		PASS

9. Alternating Hot and Humid Test

Test Conditions:

1. Operate at 85°C + 93% RH for 4h;
 2. Operate at 25°C + 93% RH for 4h;
- Cycle step 1 and step 2, a total of 2 cycles.

Test Profile:

Is Power Off ——

Is Power On ——

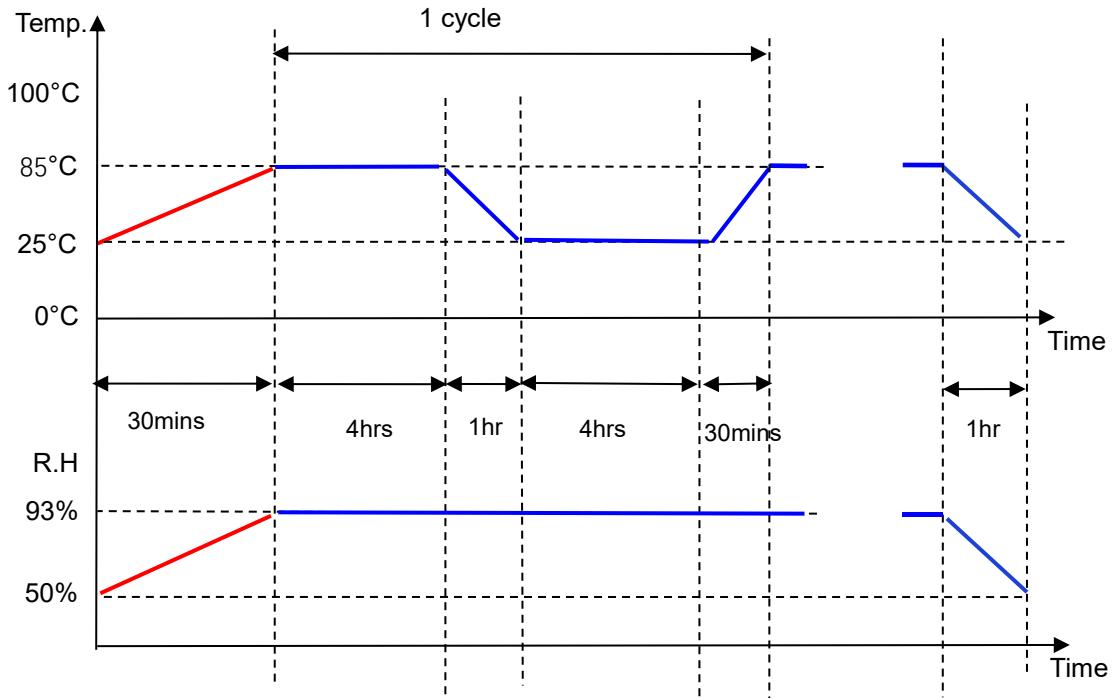

Test Criteria:

1. After connecting the module, the waveforms and distance on the interface are changing, indicating the radar is working properly. Therefore, the module function is considered to be functional.
2. After the test, the product shows no visible damage such as shrinkage, peeling, or discoloration.

Sample Quantity	Test Data	Test Results
6PCS		PASS

10. Thermal Shock Test

Test Conditions:

Power-off test. Temperature cycling between -40–100°C + 93% RH, with a heating time of 50min and a cooling time of 2h. Each stage is held for 30min, for a total of 5 cycles.

Test Profile:

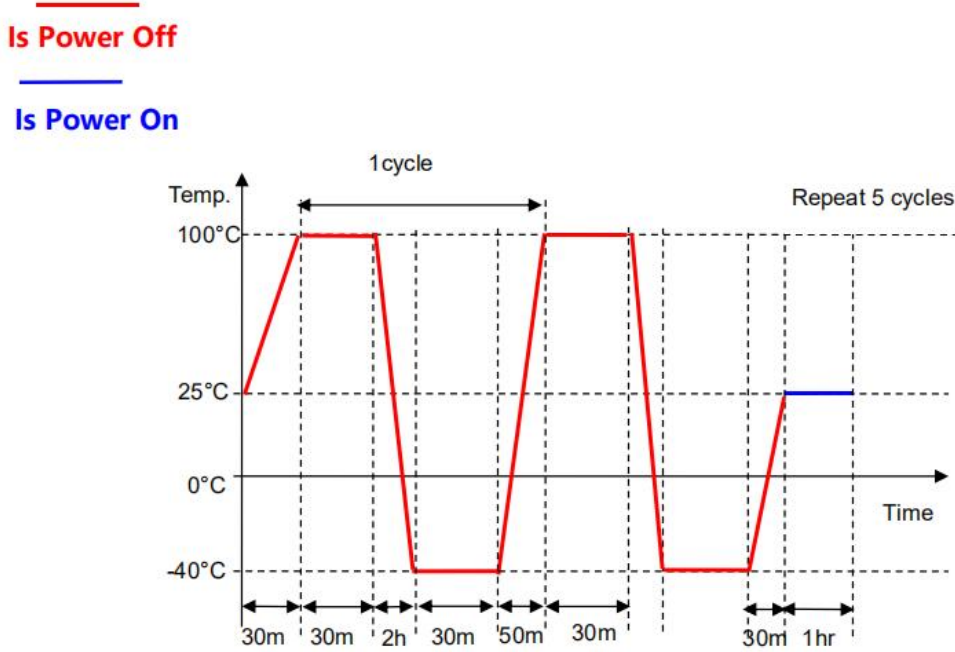

Test Criteria:

1. After connecting the module, the waveforms and distance on the interface are changing, indicating the radar is working properly. Therefore, the module function is considered to be functional.
2. After the test, the product shows no visible damage such as shrinkage, peeling, or discoloration.

Sample Quantity	Test Data	Test Results
6PCS	<p>The test data section contains six screenshots of the radar interface. Each screenshot shows a target distance and a corresponding waveform graph. The target distances are: 2.20m, 2.89m, 2.68m, 2.09m, 2.05m, and 3.20m. Each screenshot also includes a '距离VS时间' (Distance vs. Time) graph showing a stable signal over time.</p>	PASS