

Reliability Test Report

Product Name:	Radar Series
Product Model:	Rd-61 V1.1
Test Date:	2025.02.12-2025.02.22
Tested by:	Dong Wenchao
Reviewed by:	An Sanchao

1. Inspection Standard

No.	Process Name	Inspection Item	Inspection Equipment	Sampling Level (Refer to GB/T 2828.1-2012)	Acceptable Quality Level		
					CR (Critical Defect)	MA (Major Defect)	MI (Minor Defect)
1	Reliability test	High/low temperature storage; high/room/low temperature power on/off; high/low temperature operation; alternating hot and humid; thermal shock	Constant temperature and humidity chamber	Normal single sampling, special inspection S-1	0 accept, 1 reject		

2. Test Items

No.	Item	Test Conditions
1	Low temperature storage test	Test Conditions: -40°C Test duration: 8h After a 1-hour soak at -40°C, perform a cold start test.
2	High temperature storage test	Test conditions: 100°C + 93% RH Test duration: 8h After restoring to 85°C and a 1-hour soak, perform a hot start test.
3	Low temperature operation test	Test Conditions: -40°C Test duration: 24h
4	High temperature operation test	Test Conditions: 85°C + 93% RH Test duration: 24h
5	AC power on/off test with temperature	A) Temperature: -40°C B) Temperature: 25°C + 93% RH C) Temperature: 85°C + 93% RH Cycle each condition 200 times, with 30s ON and 30s OFF
6	Alternating hot and humid test	A) Operate at 85°C + 93% RH for 4h; B) Operate at 25°C + 93% RH for 4h; Cycle steps A and B for a total of 2 cycles.
7	Thermal shock test	Test conditions: -40°C–100°C + 93% RH, soak for 30min at each temperature Temperature transition time: 50min for heating, 2h for cooling. Test duration: 5 cycles

3. Test Preparation

No.	Item	Image/Attachment
1	Reliability documentation	 <p>Rd-61模组 可靠性测试说明20</p>
2	Test equipment	
3	Sample placement	
4	Test reason	New product (96010049) reliability test

4. Low Temperature Storage Test

Test Conditions: Power-off test. Store the product at -40°C for 8h, then perform a cold start test.

Test Profile:

Is Power Off ———
Is Power On ———

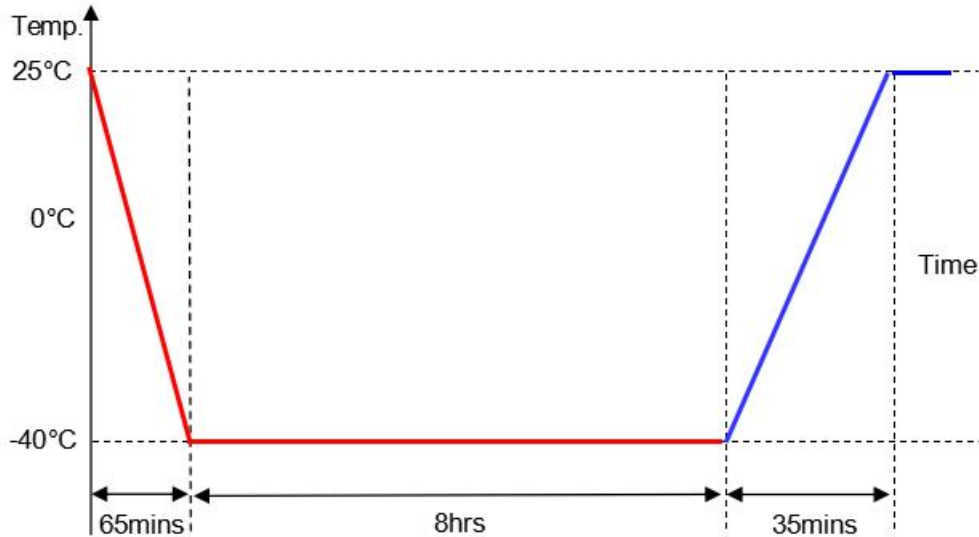

Test Criteria:

1. Open the serial port during the cold start, then click RTS and then cancel it. The serial tool prints the startup information, and after about ten seconds, range information is output through the serial port. During the test, if the serial port information is printed normally, the module is considered to be operating normally.

2. After the test, the product shows no visible damage such as shrinkage, peeling, or discoloration.

Sample Quantity	Test Data	Test Results
6PCS		PASS

5. High Temperature Storage Test

Test Conditions: Power-off test. Store the product at 100°C + 93% RH for 8h, then restore it to 85°C + 93% RH for a 1-hour soak, and perform a hot start test.

Test Profile:

Is Power Off ——
Is Power On ——

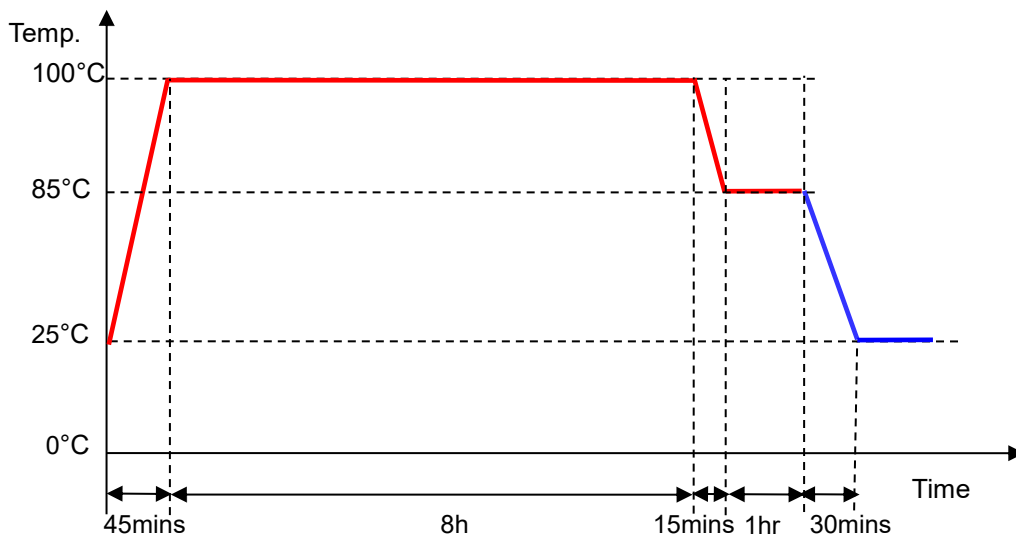

Test Criteria:

1. Open the serial port during the hot start, then click RTS and then cancel it. The serial tool prints the startup information, and after about ten seconds, range information is output through the serial port. During the test, if the serial port information is printed normally, the module is considered to be operating normally.
2. After the test, the product shows no visible damage such as shrinkage, peeling, or discoloration.

Sample Quantity	Test Data	Test Results
6PCS		PASS

6. Low Temperature Operation Test

Test Conditions: Power-on test. Operate at -40°C for 24h.

Test Profile:

Is Power Off ————

Is Power On ————

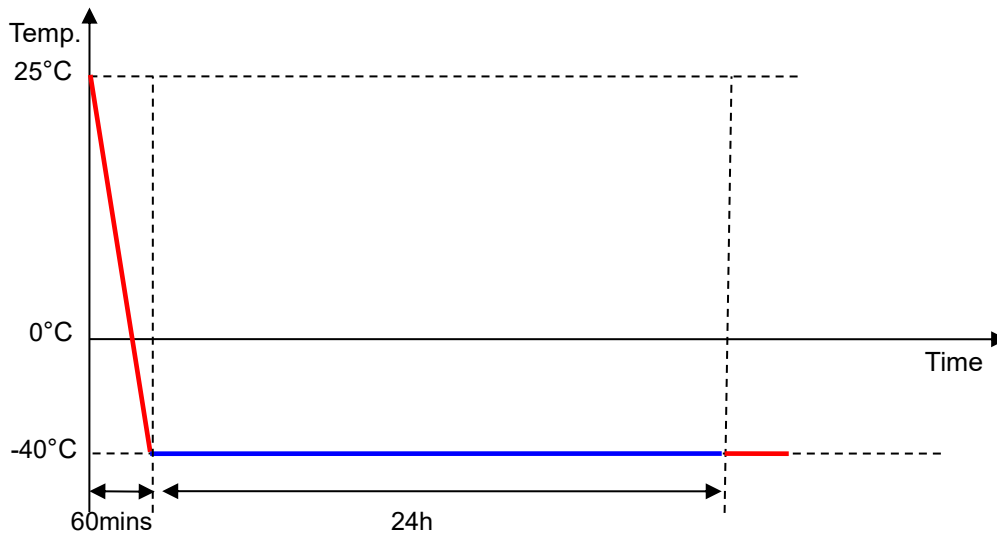

Test Criteria:

1. Open the serial port, then click RTS and then cancel it. The serial tool prints the startup information, and after about ten seconds, range information is output through the serial port. During the test, if the serial port information is printed normally, the module is considered to be operating normally.
2. After the test, the product shows no visible damage such as shrinkage, peeling, or discoloration.

Sample Quantity	Test Data	Test Results
6PCS		PASS

7. High Temperature Operation Test

Test Conditions: Power-on test. Operate at 85°C+ 93% RH for 24h.

Test Profile:

Is Power Off ——
Is Power On ——

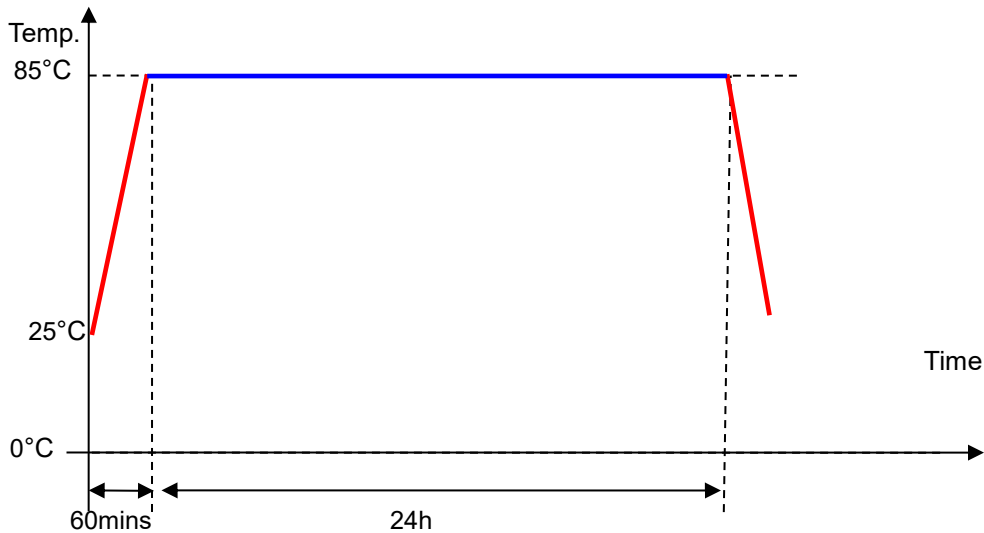

Test Criteria:

1. Open the serial port, then click RTS and then cancel it. The serial tool prints the startup information, and after about ten seconds, range information is output through the serial port. During the test, if the serial port information is printed normally, the module is considered to be operating normally.
2. After the test, the product shows no visible damage such as shrinkage, peeling, or discoloration.

Sample Quantity	Test Data	Test Results
6PCS		PASS

8. AC Power On/Off Test with Temperature

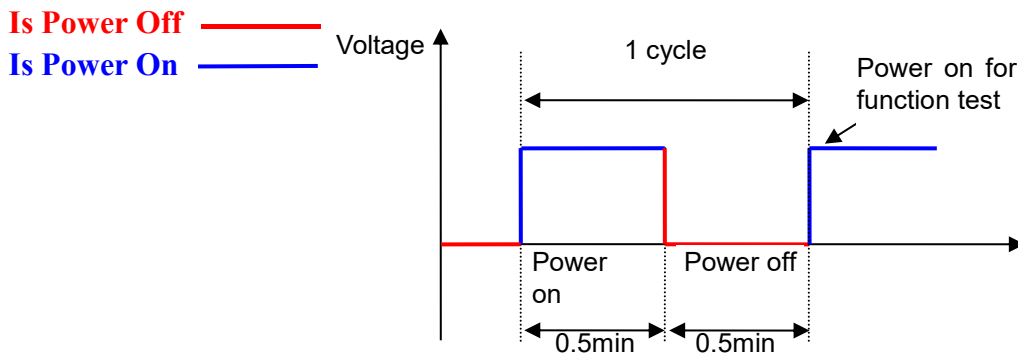

- Test Conditions:**
1. Power on: 30s; power off: 30s.
 2. Temperature: -40°C, 25°C + 93% RH, 85°C + 93% RH.
 3. Cycle: Each test condition cycles 200 times.

Test Profile:

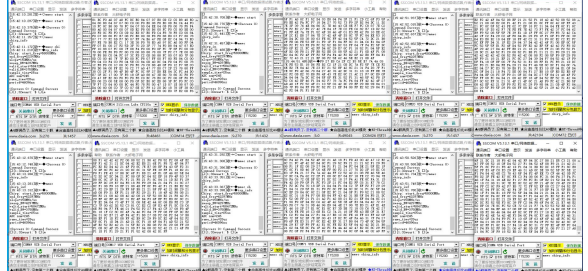

Test Criteria:

1. Open the serial port, then click RTS and then cancel it. The serial tool prints the startup information, and after about ten seconds, range information is output through the serial port. During the test, if the serial port information is printed normally, the module is considered to be operating normally.
2. After the test, the product shows no visible damage such as shrinkage, peeling, or discoloration.

Item	Sample Quantity	Test Data	Test Results
Power on/off at room temperature	6PCS		PASS
Power on/off at low temperature	6PCS		PASS
Power on/off at high temperature	6PCS		PASS

9. Alternating Hot and Humid Test

Test Conditions:

1. Operate at 85°C + 93% RH for 4h;
 2. Operate at 25°C + 93% RH for 4h;
- Cycle step 1 and step 2, a total of 2 cycles.

Test Profile:

Is Power Off —

Is Power On —

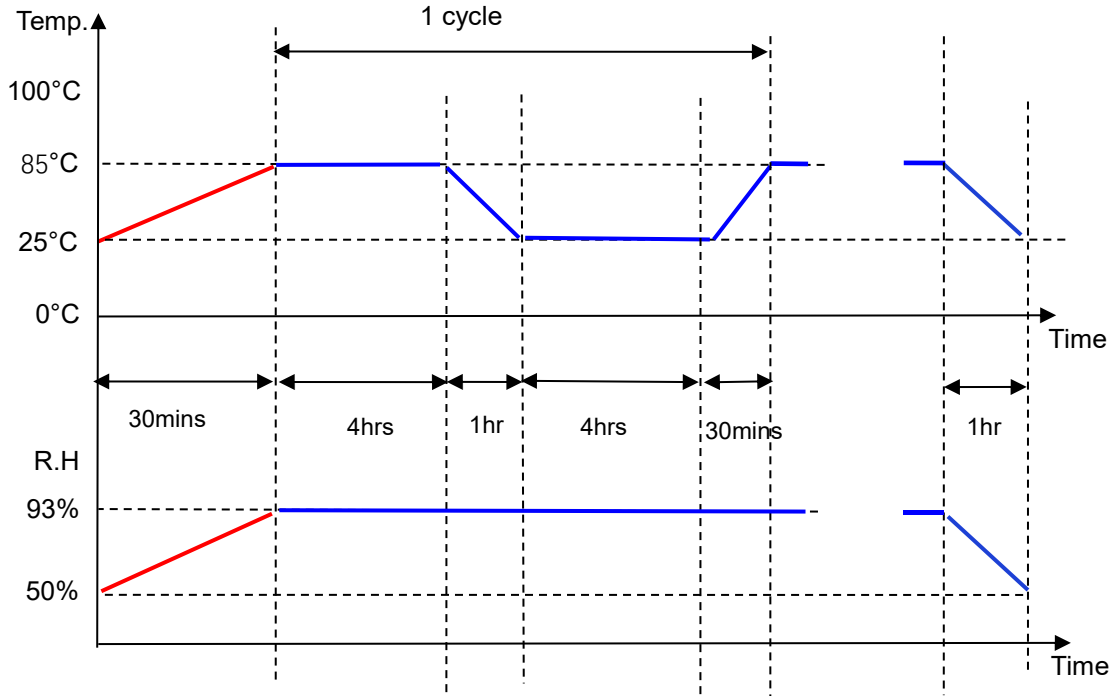

Test Criteria:

1. Open the serial port, then click RTS and then cancel it. The serial tool prints the startup information, and after about ten seconds, range information is output through the serial port. During the test, if the serial port information is printed normally, the module is considered to be operating normally.
2. After the test, the product shows no visible damage such as shrinkage, peeling, or discoloration.

Sample Quantity	Test Data	Test Results
6PCS		PASS

10. Thermal Shock Test

Test Conditions:

Power-off test. Temperature cycling between -40–100°C + 93% RH, with a heating time of 50min and a cooling time of 2h. Each stage is held for 30min, for a total of 5 cycles.

Test Profile:

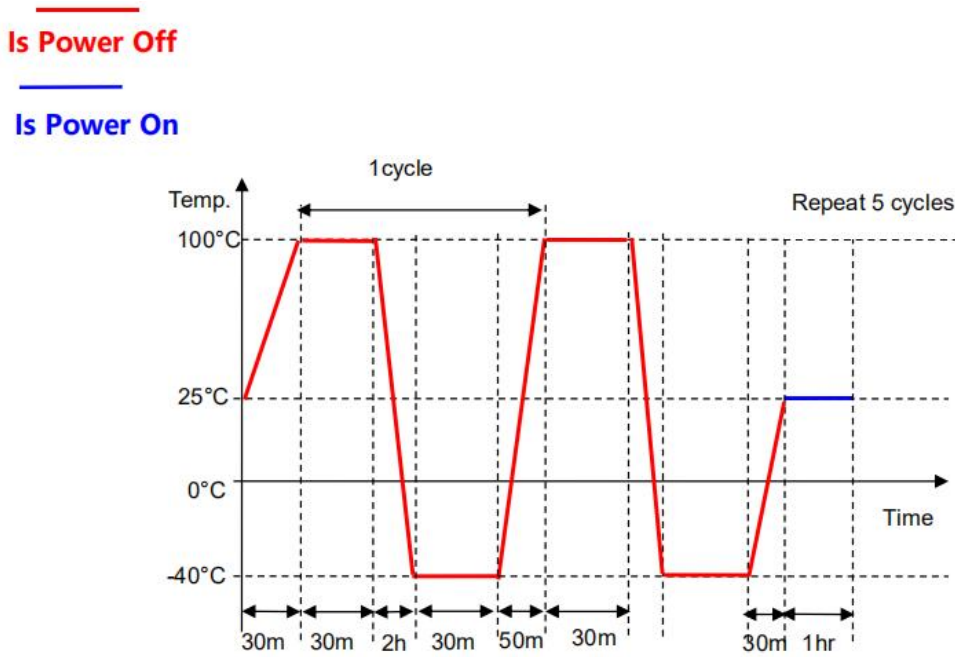

Test Criteria:

1. Open the serial port, then click RTS and then cancel it. The serial tool prints the startup information, and after about ten seconds, range information is output through the serial port. During the test, if the serial port information is printed normally, the module is considered to be operating normally.
2. After the test, the product shows no visible damage such as shrinkage, peeling, or discoloration.

Sample Quantity	Test Data	Test Results
6PCS		PASS