



Ra-01S Specification

Version V1.1.2

Copyright ©2025

Document Revision History

Version	Date	Description of Changes	Authored by	Approved by
V1.0	2020.08.12	First edition	Xu Hong	
V1.1	2020.08.19	Updated partial parameters	Xu Hong	
V1.1.2	2025.09.08	1. Updated module dimension drawing, and added thickness illustration; 2. Updated chip model to SX126x; 3. Added power consumption data; 4. Added design guide contents	Guan Ning	Xu Hong

Contents

1 Product Overview	4
2 Main Parameters	5
3 Appearance and Dimensions	8
4 Pin Definition	9
5 Schematic Diagram	10
6 Design Guide	11
7 FAQ	14
8 Storage Conditions	15
9 Reflow Soldering Profile	15
10 Packaging Information	16
11 Contact Information	16
Disclaimer and Copyright Notice	17
Notice	17
Statement	18

1 Product Overview

Ra-01S is a LoRa module designed and developed by Shenzhen Ai-Thinker Technology Co., Ltd.. This module is designed for ultra-long-range spread spectrum communication. Its SX126x RF chip primarily utilizes LoRa™ long-range modem technology, offering strong anti-interference capabilities and minimizing current consumption to the greatest extent possible. Leveraging SEMTECH's patented LoRa™ modulation technology, the SX126x achieves a theoretical sensitivity exceeding -148dBm and a power output of +22dBm, offering extended transmission distance and high reliability. Furthermore, compared with conventional modulation techniques, LoRa™ modulation demonstrates significant advantages in blocking immunity and selectivity, addressing the challenges of balancing range, interference resistance, and power consumption that traditional design solutions cannot simultaneously achieve.

It can be widely used in automatic meter reading, home and building automation, security systems, remote irrigation systems, and other applications.

Features

- LoRa™ modem
- Supports FSK, GFSK, MSK, GMSK, LoRa™ and OOK modulation
- Supports 410–525MHz frequency band
- Operating voltage is 3.3V; maximum output power is +22dBm; maximum operating current is 140mA
- Features low power consumption in receive mode, with a minimum receive current of 4.2mA and a standby current of 1.6mA.
- High sensitivity: it can reach down to -148dBm theoretically
- Ultra-compact dimensions in a dual-row castellated (stamp hole) SMT package
- Adopts SPI interface, half-duplex communication, with CRC and a data packet engine supporting up to 256 bytes

2 Main Parameters

Table 1 Main Parameters Specification

Model	Ra-01S
Package	SMD16
Dimensions	17*16*3.3 (mm)
Antenna Type	Compatible with half-hole pads / through-hole pads (antenna needs to be soldered) / IPEX connector
Frequency Range	410–525MHz
Operating Temperature	-40–85°C
Storage Conditions	-40–125°C, < 90% RH
Power Supply Range	2.7–3.6 V, typical value 3.3 V, current > 200mA
Supported Interfaces	SPI
Programmable Bit Rate	Up to 300kbps
Certification	FCC, CE

2.1 ESD Requirements

Ra-01S is an ESD-sensitive device and requires special precautions during handling.



Figure 1 ESD Protection Symbol

Note:

The Ra-01S module is an ESD-sensitive device and requires special ESD precautions. It should normally be handled as an ESD-sensitive component. Proper ESD handling and packaging procedures must be followed throughout the entire process of handling, transportation, and operation of any application involving the Ra-01S module. Do not touch the module directly with bare hands or solder it using a non-ESD-safe soldering iron, as this may damage the module.

2.2 Electrical Characteristics

Table 2 Electrical Characteristics

Parameter	Name	Min	Typ	Max	Unit
Operating Temperature	TOPR	-40	25	85	°C
Supply Voltage	VDD	2.7	3.3	3.6	V

Table 3 Digital Port Characteristics

Description		Typ		Unit	
Operating Frequency		410–525		MHz	
Port	Name	Min	Typ	Max	Unit
I/O Level	VIO	2.7	3.3	3.6	V
Input Low Level	VIL	-	-	0.2	V
Input High Level	VIH	0.8	-	-	V
Output Low Level	VOL	-	-	0.1	V
Output High Level	VOH	0.9	-	-	V

Table 4 SPI Interface Characteristics

Symbol	Description	Condition	Min	Typ	Max	Unit
Fsck	SCK Frequency	-	-	-	10	MHz
tch	SCK High-Level Time	-	50	-	-	ns
tcl	SCK Low-Level Time	-	50	-	-	ns
trise	SCK Rise Time	-	-	5	-	ns
tfall	SCK Fall Time	-	-	5	-	ns
tsetup	MOSI Setup Time	From MOSI change to SCK rising edge	30	-	-	ns
thold	MOSI Hold Time	From SCK rising edge to MOSI change	20	-	-	ns
tnsetup	NSS Setup Time	From NSS falling edge to SCK rising edge	30	-	-	ns
tnhold	NSS Hold Time	From SCK falling edge	100	-	-	ns

		to NSS rising edge, normal mode				
tnhigh	SPI Access Interval NSS High Time	-	20	-	-	ns
T_DATA	DATA Hold and Setup Time	-	250	-	-	ns

Table 5 Power Consumption

The following power consumption data are measured based on a 3.3V power supply and an ambient temperature of 25°C.

Mode	Min	Typ	Max	Unit
TX Mode	-	110	-	mA
RX Mode	-	9.8	-	mA
Deep Sleep	-	1.3	-	μA

3 Appearance and Dimensions

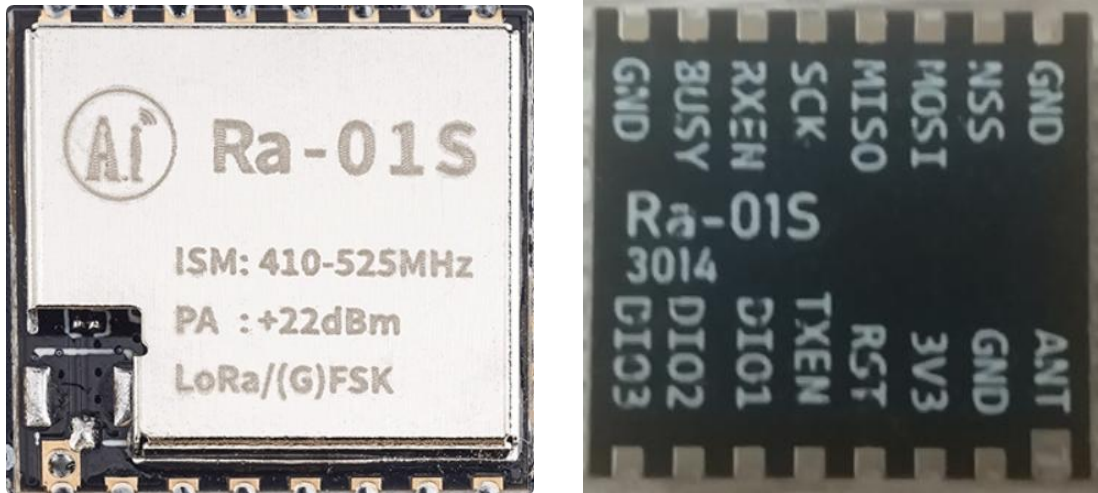

Figure 2 Appearance Diagram

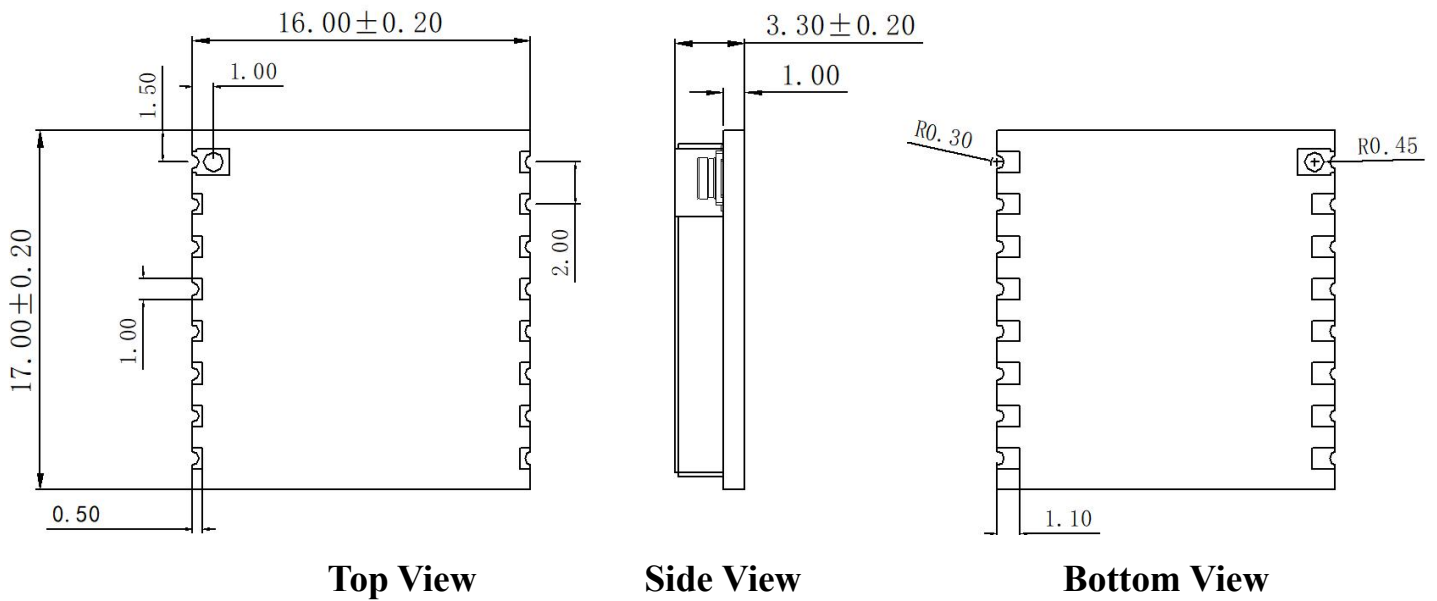

Figure 3 Dimension Diagram (Unit: mm)

4 Pin Definition

The Ra-01S module exposes a total of 16 pins, as shown in the pin diagram. The pin function definition table provides the detailed interface specifications.



Figure 4 Pin Diagram

Table 6 Pin Function Definition

No.	Name	Function Description
1	ANT	Antenna interface
2	GND	Ground
3	3.3V	3.3V power supply, typical
4	RESET	Reset pin
5	TXEN	RF control pin
6	DIO1	Digital IO1 software configurable
7	DIO2	Digital IO2 software configurable
8	DIO3	Digital IO3 software configurable
9	GND	Ground
10	BUSY	Status indicator pin
11	RXEN	RF control pin
12	SCK	SPI clock input
13	MISO	SPI data output

14	MOSI	SPI data input
15	NSS	SPI chip select input
16	GND	Ground

All three general-purpose I/O pins of the SX126x are available in LoRa™ mode. Their function mapping is determined by the configuration of the RegDioMapping1 and RegDioMapping2 registers.

Figure 7 I/O Function Mapping

Operating Mode	DIOx Mapping	DIO3	DIO2	DIO1
All	00	CadDone	Fhss Change Channel	RxRimeout
	01	Valid Header	Fhss Change Channel	Fhss Change Channel
	10	PayloadCrc Error	Fhss Change Channel	CadDetected
	11	-	-	-

5 Schematic Diagram

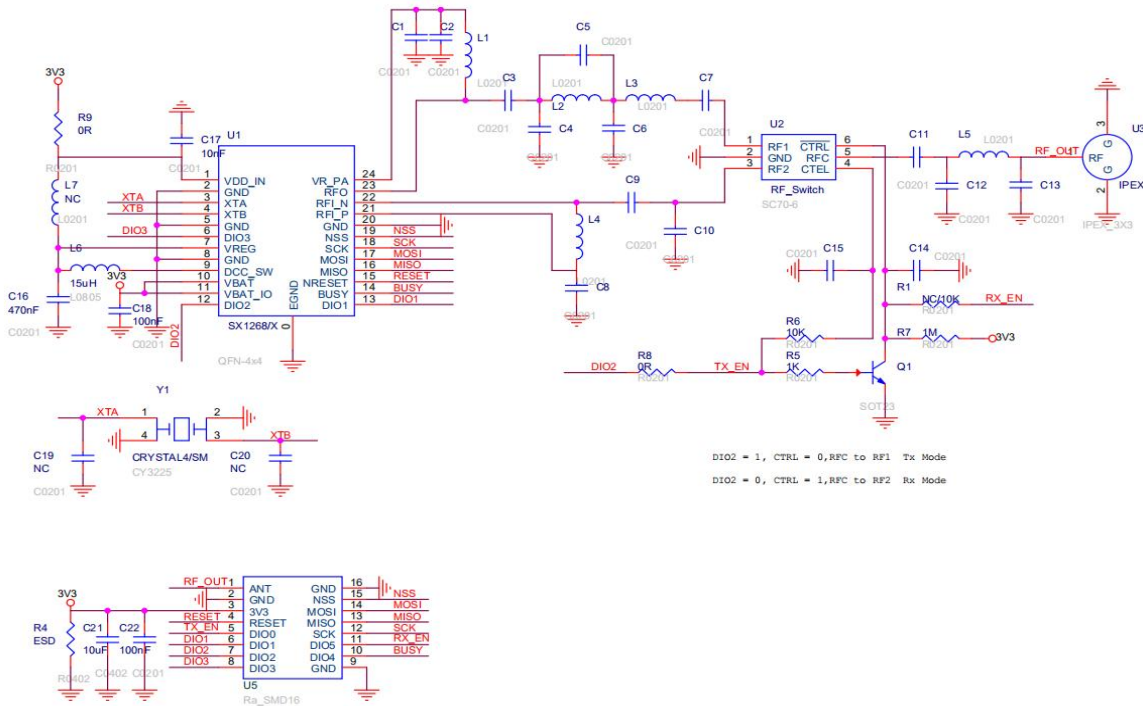

Figure 5 Schematic Diagram

6 Design Guide

6.1 Application Circuit

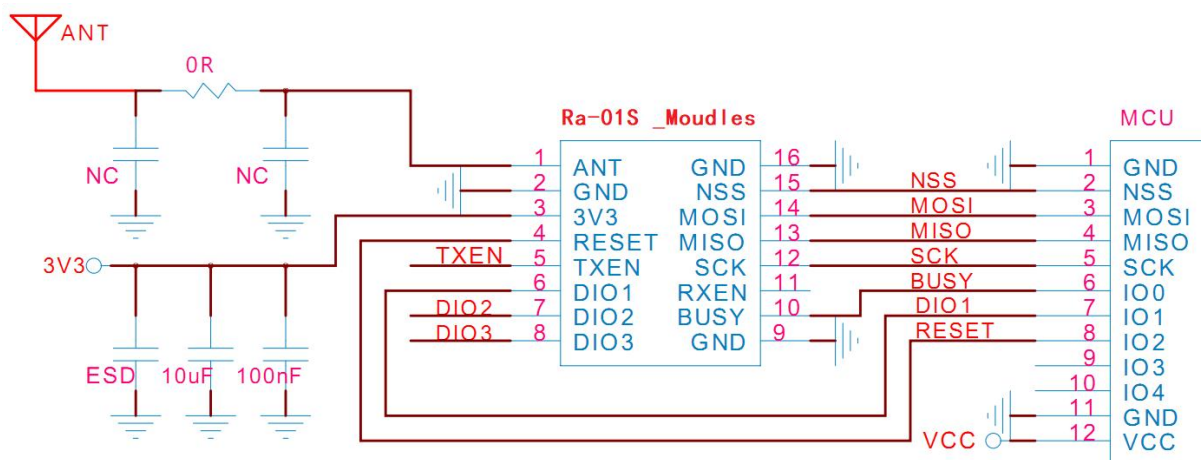

Figure 6 Application Circuit

- (1) Besides the SPI interface, connect BUSY/DIO1 to the I/O pins of the host MCU.

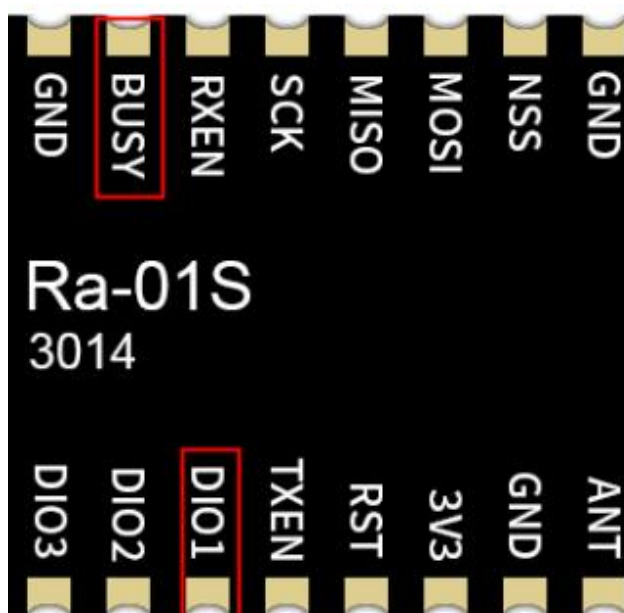

Figure 7 BUSY/DIO1 Application Notes

- (2) The antenna is soldered on the mainboard. It is recommended to reserve a π -type matching circuit at the antenna interface.

6.2 Recommended PCB Footprint Dimensions

Note: This diagram shows the package outline of the Ra-01S module. It is recommended to design the PCB board according to this diagram to ensure the module can work properly on the PCB. When designing the solder pads, it is important to note that the solder pads on the PCB

should not be designed to be retracted relative to the corresponding module solder pads. However, if the PCB solder pads are expanded relative to the module solder pads, it will not affect the use of the module.

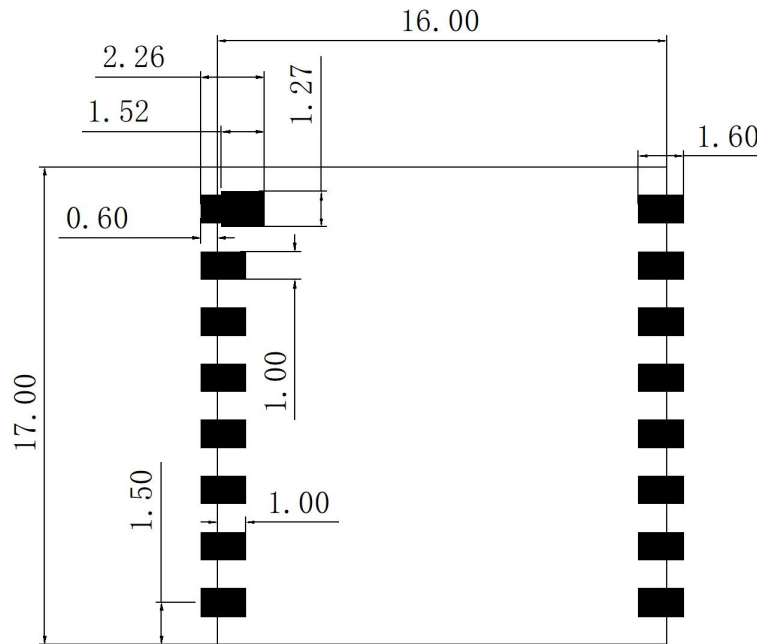

Figure 8 Recommended PCB Footprint Dimensions (Unit: mm)

6.3 Antenna Installation

- (1) The antenna must be soldered for use with the Ra-01S. And the module is compatible with half-hole pads, round-hole pads, and IPEX connectors.
- (2) To achieve optimal antenna performance, the antenna assembly should be kept away from any metal objects.

6.4 Power Supply

- (1) A 3.3V voltage is recommended, with a peak current above 200mA.
- (2) An LDO is recommended for power supply; if using DC-DC, the ripple should be controlled within 30mV.
- (3) For the DC-DC power supply circuit, it is recommended to reserve space for dynamic response capacitors to optimize output ripple under large load transients.
- (4) It is recommended to add ESD protection devices to the 3.3V power interface.

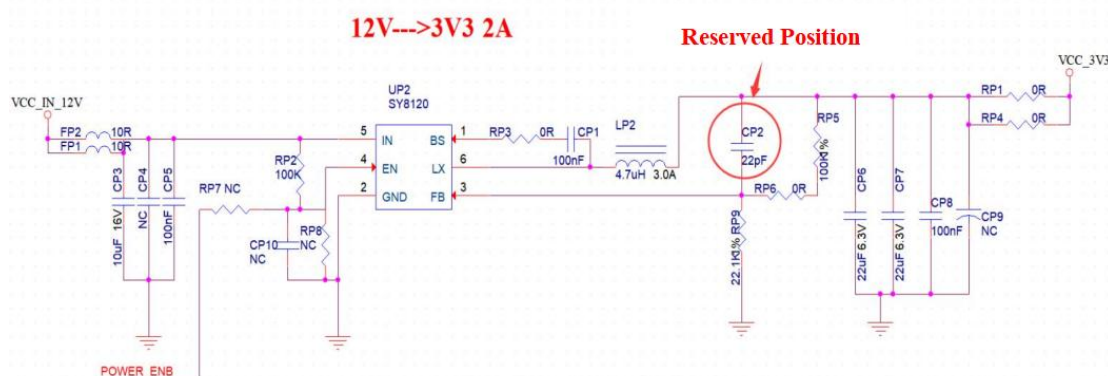

Figure 9 DC-DC Buck Circuit

6.5 GPIO

- (1) Some I/O pins are exposed on the module periphery. To use these I/O pins, it is recommended to connect a 10-100Ω resistor in series with each I/O pin. This helps suppress overshoot, stabilize signal levels, and benefits both EMI and ESD protection.
- (2) The pull-up or pull-down configuration for special I/O pins must follow the guidelines in the specification, as it affects the module's boot configuration.
- (3) The module's I/O pins operate at 3.3V. If the IO voltage level of the main controller and the module do not match, a level-shifting circuit must be added.
- (4) If an I/O pin is directly connected to a peripheral interface or pin headers, it is recommended to reserve space for an ESD protection device near the connector on the I/O trace.

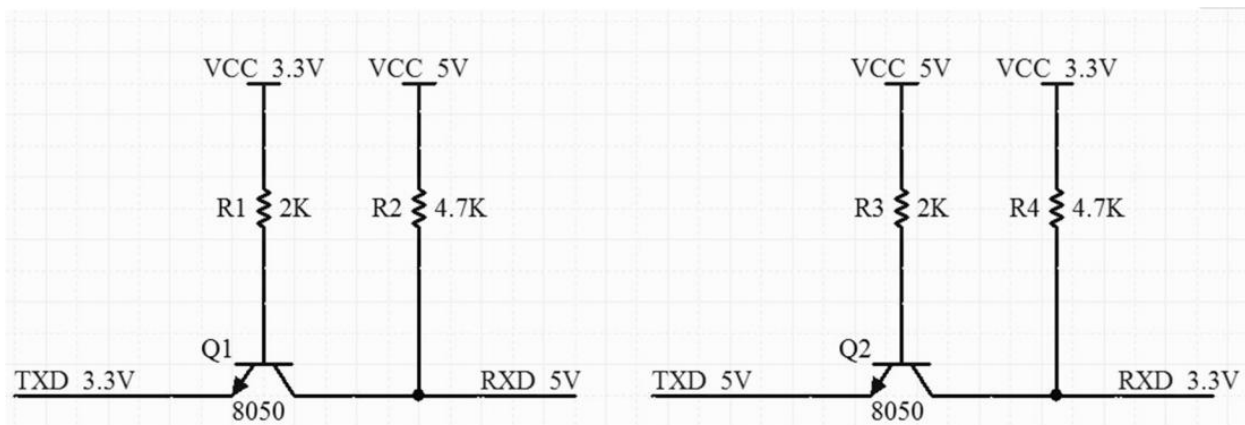

Figure 10 Level-shifting Circuit

6.6、 Software Programming

■ Differences Between LLCC68 and SX126x:

(1) SX126x

Supports spreading factors SF5, SF6, SF7, SF8, SF9, SF10, SF11, SF12;

SX126x configurable spreading factor and receiver bandwidth:

LoRa@Rx/Tx, BW = 7.8–500kHz;

SF5 to SF12, BR = 0.018–62.5kb/s.

(2) LLCC68

Supports spreading factors SF5, SF6, SF7, SF8, SF9, SF10, SF11;

LLCC68 configurable spreading factor and receiver bandwidth:

LoRa@ Rx/Tx, BW = 125 / 250 / 500kHz,

LoRa@ , SF = 5/6/7/8/9 for BW = 125kHz,

LoRa@ , SF = 5/6/7/8/9/10 for BW = 250kHz,

LoRa@ , SF = 5/6/7/8/9/10/11 for BW = 500kHz.

7 FAQ

7.1 Factors Affecting Transmission Range

- (1) Communication range will be attenuated accordingly when direct line-of-sight obstructions exist.
- (2) Temperature, humidity, and co-channel interference will increase the packet loss rate.
- (3) The ground absorbs and reflects radio waves, resulting in poor performance when testing near the ground.
- (4) Seawater has a strong ability to absorb radio waves, resulting in poor performance in coastal testing.
- (5) Metal objects near the antenna or placing it in a metal enclosure will cause severe signal attenuation.
- (6) Incorrect power register settings or setting the over-the-air (OTA) data rate too high (higher OTA rates correspond to shorter transmission ranges).
- (7) Power supply voltage is below the recommended voltage at room temperature; the lower the voltage, the less the transmit power.
- (8) The matching between the antenna and the module is poor, or there are quality issues with the antenna itself.

7.2 Module Usage Precautions

- (1) Check the power supply to ensure the voltage is within the recommended range. Exceeding the maximum rating may cause permanent damage to the module.
- (2) Check the stability of the power supply, ensuring that the voltage does not fluctuate significantly and frequently.
- (3) Ensure electrostatic discharge (ESD) precautions are followed during installation and use, as high-frequency components are electrostatic sensitive.
- (4) Ensure the humidity is not excessively high during installation and use, as some components are moisture-sensitive.
- (5) Unless there are special requirements, it is not recommended to use the product at excessively high or low temperatures.

7.3 Factors Causing Interference to the Module

- (1) Co-channel signal interference nearby. Move away from the interference source, or change the frequency/channel to avoid interference.
- (2) Non-standard SPI clock waveform. Check for interference on the SPI lines, and ensure the SPI bus traces are not excessively long.
- (3) Non-ideal power supply may also cause garbled data; ensure the power supply is highly reliable.
- (4) Poor quality or excessively long extension cables/feeder lines can also result in a high bit error rate.

8 Storage Conditions

Products sealed in moisture barrier bags should be stored in a non-condensing atmosphere at $<40^{\circ}\text{C}$ and $< 90\% \text{ RH}$.

The moisture sensitivity level (MSL) of the module is level 3.

The module must be used within 168 hours after vacuum bag removal under conditions of $25\pm 5^{\circ}\text{C}$ and 60% RH. Otherwise, the module requires baking before being returned to production.

9 Reflow Soldering Profile

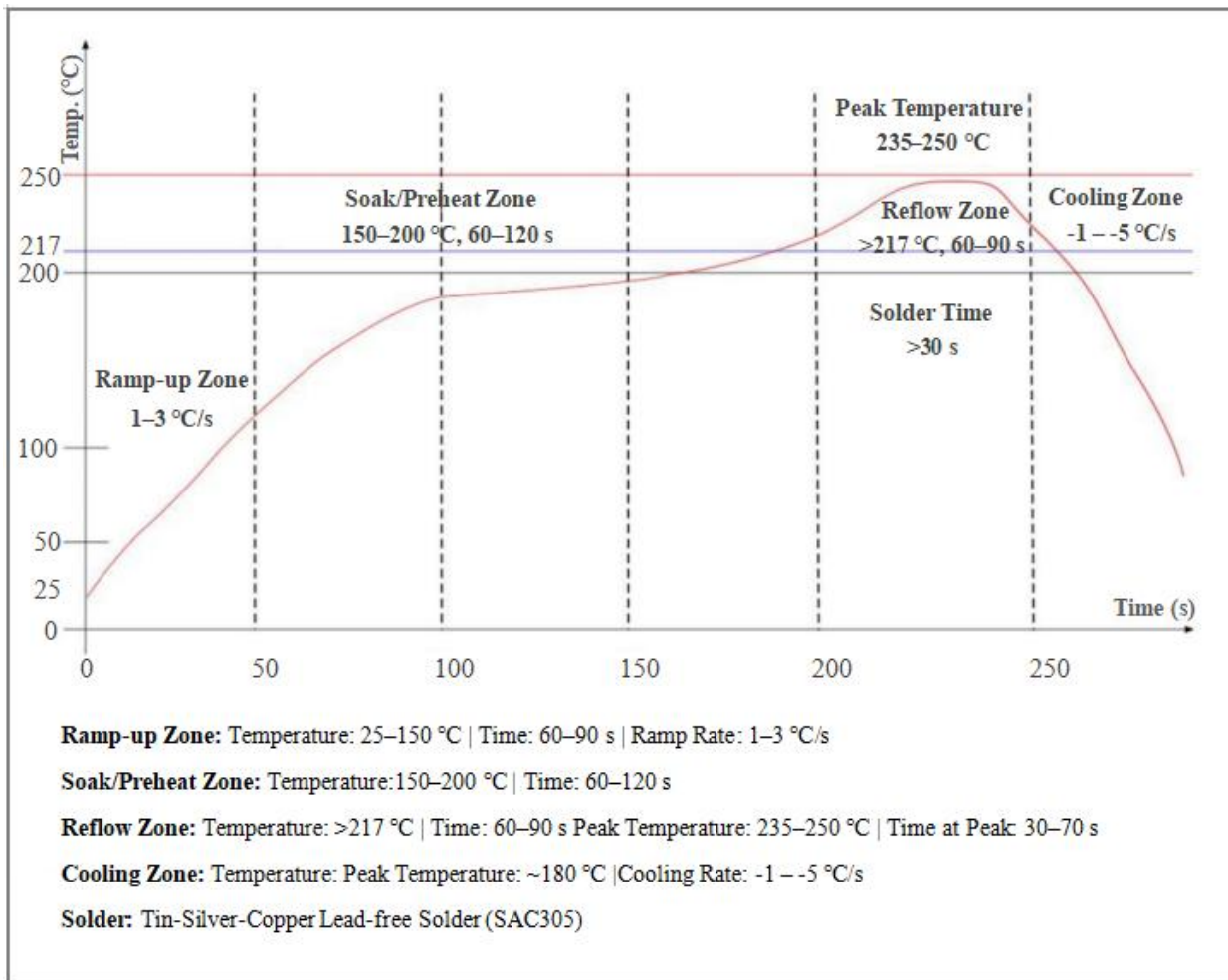

Figure 11 Reflow Soldering Profile

10 Packaging Information

As shown below, the Ra-01S module is packaged in tape and reel, with 800pcs/reel.



Figure 11 Tape and Reel Packaging Diagram

11 Contact Information

[Official Website](#)

[Official Forum](#)

[Development DOCS](#)

[LinkedIn](#)

[Tmall Store](#)

[Taobao Store](#)

[Alibaba Store](#)

[Technical Support: support@aithinker.com](mailto:support@aithinker.com)

[Domestic Business Cooperation: sales@aithinker.com](mailto:sales@aithinker.com)

[Overseas Business Cooperation: overseas@aithinker.com](mailto:overseas@aithinker.com)

Company Address: Room 403-405, 408-410, Building C, Huafeng Smart Innovation Port, Gushu, Xixiang, Bao'an District, Shenzhen, Guangdong, China

Contact Hotline: 0755-29162996



WeChat Mini Program



WeChat Official Account

Disclaimer and Copyright Notice

The information in this document, including referenced URLs, is subject to change without notice.

The document is provided “as is” without warranty of any kind, express or implied, including but not limited to the warranties of merchantability, fitness for a particular purpose, or non-infringement. Furthermore, no warranty is given regarding proposals, specifications, or samples mentioned elsewhere. The publisher bears no responsibility, including for any infringement of patent rights arising from the use of information contained herein. This document does not grant, expressly or impliedly, by estoppel or otherwise, any license to intellectual property rights.

All test data presented herein are obtained from Ai-Thinker laboratories. Actual results may vary slightly.

All trade names, trademarks, and registered trademarks mentioned are the property of their respective owners.

Shenzhen Ai-Thinker Technology Co., Ltd. reserves the final right of interpretation of this document.

Notice

This manual may be updated due to product version upgrades or other reasons.

Shenzhen Ai-Thinker Technology Co., Ltd. reserves the right to modify the content of this manual without prior notice or announcement.

This manual is intended as a usage guide only. While Shenzhen Ai-Thinker Technology Co., Ltd. strives to provide accurate information, it does not guarantee that the content is entirely free of errors. All statements, information, and recommendations in this manual do not constitute any express or implied warranty.

Statement

Shenzhen Ai-Thinker Technology Co., Ltd. (hereinafter “Ai-Thinker”) may provide all technical and reliability data (including datasheets), design resources (including reference designs), application or other design advice, web tools, security information, and other resources (collectively referred to as “these Resources”) on an “as is” basis, without warranty of any kind, express or implied, including but not limited to warranties of merchantability, fitness for a particular purpose, or non-infringement of any third-party intellectual property rights. Ai-Thinker specifically disclaims any liability for losses, whether direct or consequential, arising from the application or use of any Ai-Thinker products or circuits.

Ai-Thinker reserves the right to modify the content of this document (including but not limited to specifications and product descriptions) and any related products without prior notice. This document automatically supersedes and replaces all previous versions of the same document number.

These Resources are intended for use by skilled developers designing with Ai-Thinker products. You are solely responsible for: (1) Selecting the appropriate Ai-Thinker products for your application; (2) Designing, validating, and operating your application and product throughout its life cycle; (3) Ensuring your application complies with all applicable standards, laws, and any other functional safety, information security, regulatory, or other requirements.

Ai-Thinker may authorize you to use these Resources solely for developing applications incorporating the Ai-Thinker products described herein. No part of these Resources may be copied, reproduced, or distributed in any form without prior written permission from Ai-Thinker. You are not permitted to use any other intellectual property of Ai-Thinker or any third party. You shall fully indemnify Ai-Thinker and its representatives against any claims, damages, costs, losses, or liabilities arising from your use of these Resources, for which Ai-Thinker assumes no liability.

Ai-Thinker’s products are supplied under Ai-Thinker’s general sales terms and conditions or other applicable terms accompanying the products. The provision of these Resources does not expand or otherwise alter the warranties or warranty disclaimers applicable to the product as delivered.