



Rd-03L_V2 Serial Communication Protocol

Version V1.0.0

Copyright ©2025

Contents

1. Communication Interface Introduction	4
1.1 Pin Definition and Wiring	4
1.2 Configuration Parameters and Descriptions	4
2. Communication Protocol	6
2.1 Protocol format	6
2.1.1. Protocol Data Format	6
2.1.2. Upload Data Format	6
2.2 Send Command and ACK	7
2.2.1. Read Firmware Version	7
2.2.2. Enable Configuration Command	7
2.2.3. End Configuration Command	8
2.2.4. Write Serial Number Command	8
2.2.5. Read Serial Number Command	8
2.2.6. Write General Parameter Command	9
2.2.7. Read General Parameter Command	10
2.2.8. Write Trigger Threshold Parameter Command	11
2.2.9. Read Trigger Threshold Parameter Command	11
2.2.10. Write Hold Threshold Parameter Command	12
2.2.11. Read Hold Threshold Parameter Command	13
2.2.12. Automatic Threshold Generation Command	14
2.2.13. Query Automatic Threshold Generation Progress Command	14
2.3. Radar Command Configuration Method	15
2.3.1. Radar Command Configuration Steps	15
2.3.2. Radar Configuration Precautions	15
3. Contact Information	16
Disclaimer and Copyright Notice	17
Notice	17
Statement	18

1. Communication Interface Introduction

1.1 Pin Definition and Wiring

The Rd-03L_V2 module exposes a total of five pins, as shown in the pin diagram below. The pin function definition table provides the detailed interface specifications.

Figure 1 Pin Diagram

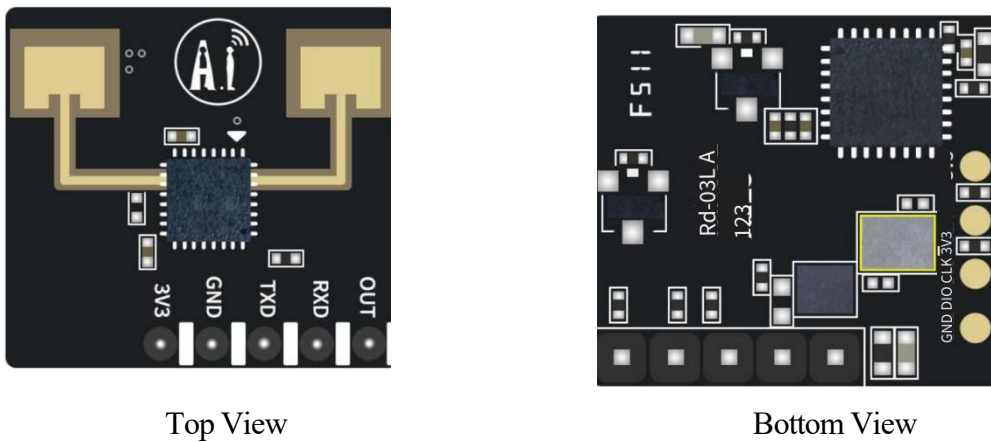

Table 1 Rd-03L_V2 Connect TTL

Rd-03L_V2	USB to TTL
3.3V	3.3V
GND	GND
TX	RXD
RX	TXD
OUT	Output high/low level based on detection results; no connection required

1.2 Configuration Parameters and Descriptions

Users can modify the configuration parameters of the Rd-03L_V2 module via its serial port to adapt to different application requirements. And the configurable radar parameters are listed in Table 2.

Table 2 Rd-03L_V2 Configuration Parameters

Parameter Name	Configurable Range	Description	Unit
Minimum Detection Distance	0–8.4	Minimum effective detection distance of the module	m
Maximum Detection Distance	0.7–8.4	Maximum effective detection distance of the module	m
Status Upload Frequency	1–8	Frequency at which the module reports occupied/unoccupied status	Hz
Distance Upload Frequency	1–8	Frequency at which the module reports target distance when occupied	Hz
Response Speed	/	Normal / Fast	/
No-person Upload Delay Time	10–120	Delay time required for the module to report a transition from occupied to unoccupied status	s
Trigger Threshold	10–95	Absolute energy threshold for detecting movement from unoccupied to occupied status within 0–15m range	dB
Hold Threshold	10–95	Absolute energy threshold for detecting stationary human body and maintaining occupied status within 0–15m range	dB

2. Communication Protocol

This communication protocol is primarily provided for users who do not rely on visualization tools. The Rd-03L_V2 communicates with external devices via a serial port (TTL level). All data output and configuration commands for the radar are performed under this protocol. The default serial baud rate of the radar is 256000, with 1 stop bit and no parity check.

2.1 Protocol format

2.1.1. Protocol Data Format

The serial data communication of the Rd-03L_V2 uses little-endian format. All data in the following tables is represented in hexadecimal.

2.1.2. Upload Data Format

The Rd-03L_V2 supports three types of data upload formats: minimal data upload format, standard data upload format, automatic threshold progress data upload format. By default, the module uses the minimal data upload format. The standard data upload format is intended for use with upper-level software tools. And the automatic threshold progress data upload format is used only when generating automatic thresholds.

Table 5-1 Data Upload Format

Minimal Data	Frame Header	Target Status			Target Distance			Frame Trailer
	6E	1 bytes (0/1 indicates no person; 2/3 indicates person present)			2 bytes (unit: cm)			62
Standard Data	Frame Header	Frame Data Length	Data Type	Target Status	Target Distance	Reserved Bits	Door Energy Value at Each Distance	Frame Trailer
	F4 F3 F2 F1	2 bytes	0x01	1 byte (0/1 indicates no person; 2/3 indicates person present)	2 bytes (unit: cm)	2 bytes	64 bytes	F8 F7 F6 F5
Automatic Threshold Progress Data	Frame Header	Frame Data Length	Data type	Threshold Generation Progress				Frame Trailer
	F4 F3 F2 F1	2 bytes	0x03	2 bytes (progress × 100)				F8 F7 F6 F5

2.2 Send Command and ACK

2.2.1. Read Firmware Version

This command reads the firmware version information of Rd-03L V2.

Command Code: 0x0000

Command Value: None

Return Value: 2-byte major version number + 2-byte minor version number + 2-byte patch version number

Sent Data:

Frame Header	Frame Data length	Command Code	Frame Tail
FD FC FB FA	02 00	00 00	04 03 02 01

ACK (Success) :

Frame Header	Frame Data Length	Command Code	Major Version Number	Minor Version Number	Patch Version Number	Frame Tail
FD FC FB FA	08 00	00 01	0x00	0x00	0x00	04 03 02 01

2.2.2. Enable Configuration Command

Any other commands sent to the radar must be issued after this command; otherwise, they will be invalid.

Command Code: 0x00FF

Command Value: 0x0001

Return Value: 2-byte protocol version (0x0001)

Sent Data:

Frame Header	Frame Data Length	Command Code	Command Value	Frame Tail
FD FC FB FA	04 00	FF 00	01 00	04 03 02 01

Radar ACK (Success):

Frame Header	Frame Data Length	Command Code	Return Result	Protocol Version	Receive Buffer Size	Frame Tail
FD FC FB FA	08 00	FF 01	00 00	03 00	80 00	04 03 02 01

2.2.3. End Configuration Command

This command ends the configuration mode. After execution, the radar returns to normal operating mode. If other commands need to be sent again, the enable configuration command must be issued first.

Command Code: 0x00FE

Command Value: None

Return Value: 2 bytes ACK status (0 for success, other values indicate failure)

Sent Data:

Frame Header	Frame Data Length	Command Code	Frame Tail
FD FC FB FA	02 00	FE 00	04 03 02 01

Radar ACK (Success):

FD FC FB FA	04 00	FE 01	00 00	04 03 02 01
-------------	-------	-------	-------	-------------

2.2.4. Write Serial Number Command

This command writes the serial number to the sensor.

Command Code: 0x0010

Command Value: 2 bytes serial number length + 8 bytes serial number

Return Value: 2 bytes ACK status (0 success, 1 failure)

Sent Data: (Example: SN is 12345678)

Frame Header	Frame Data Length	Command Code	Serial Number Length	Serial Number	Frame Tail
FD FC FB FA	0C 00	10 00	08 00	31 32 33 34 35 36 37 38	04 03 02 01

ACK (Success):

Frame Header	Frame Data Length	Command Code	ACK	Frame Tail
FD FC FB FA	04 00	10 01	00 00	04 03 02 01

2.2.5. Read Serial Number Command

This command reads the serial number of the sensor.

Command Code: 0x0011

Command Value: None

Return Value: 2 bytes ACK status (0 success, 1 failure) + 2 bytes serial number length + 8 bytes serial number

Sent Data:

Frame Header	Frame Data Length	Command Code	Frame Tail
FD FC FB FA	02 00	11 00	04 03 02 01

ACK: (Success, Example: SN is 12345678)

Frame Header	Frame Data Length	Command Code	ACK	Serial Number Length	Serial Number	Frame Tail
FD FC FB FA	0E 00	11 01	00 00	08 00	31 32 33 34 35 36 37 38	04 03 02 01

2.2.6. Write General Parameter Command

This command is used to set the general parameters of the sensor.

Command Code: 0x0070

Command Value: (2-byte parameter code + 4-byte parameter value) × N

Return Value: 2 bytes ACK status (0 success, 1 failure)

Sent Data: (Example: “Maximum Detection Distance Threshold”=12; “Minimum Detection Distance Threshold”=0; “No Person Delay Time (seconds)”=40; “Status Upload Frequency”=1Hz; “Distance Upload Frequency”=1Hz; “Response Speed”= Normal)

Frame header	Frame Data Length	Command Code	Maximum Detection Distance Threshold	Minimum Detection Distance Threshold
FD FC FB FA	26 00	70 00	05 00 0C 00 00 00	0A 00 00 00 00 00
No Person Delay Time (seconds)	Status Upload Frequency	Distance Upload Frequency	Response Speed	Frame Tail
06 00 28 00 00 00	02 00 0A 00 00 00	0C 00 0A 00 00 00	0B 00 0A 00 00 00	04 03 02 01

ACK (Success):

Frame Header	Frame Data Length	Command Code	ACK	Frame Tail
FD FC FB FA	04 00	70 01	00 00	04 03 02 01

1. One distance threshold unit corresponds to 0.7m.

2. In this protocol, the parameter values for status/distance upload frequency are equal to the corresponding frequency $\times 10$.
3. Response speed has two states: normal and fast. The parameter value for normal is 10, and for fast it is 20. The parameter codes and value ranges for general parameters are defined in Table 5-2.

Table 5-2 Definition of General Parameter Codes and Value Ranges

Parameter Name	Parameter Code	Value Range	Unit
Maximum Detection Distance Threshold	05	1-16	-
Minimum Detection Distance Threshold	0A	0-16	-
No-person Delay Time	06	10-120	s
Status Upload Frequency	02	1-8 (1 step)	Hz
Distance Upload Frequency	0C	1-8 (1 step)	Hz
Response Speed	0B	10 (normal) / 20 (fast)	-

2.2.7. Read General Parameter Command

This command reads the configuration parameters of the sensor.

Command Code: 0x0071

Command Value: (2 bytes parameter code) \times N

Return Value: (4 bytes parameter code) \times N

Sent Data:

Frame header	Frame Header	Command Code	Maximum Detection Distance Threshold	Minimum Detection Distance Threshold
FD FC FB FA	0E 00	71 00	05 00	0A 00
No-person Delay Time	Status Upload Frequency	Distance Upload Frequency	Response Speed	Frame Tail
06 00	02 00	0C 00	0B 00	04 03 02 01

ACK: (Success example: “Maximum Detection Distance Threshold”=12; “Minimum Detection Distance Threshold”=0; “No-person Delay Time (seconds)”=40;

“Status Upload Frequency”=1Hz; “Distance Upload Frequency”=1Hz; “Response Speed”=normal)

Frame Header	Frame Data Length	Command Code	ACK	Maximum Detection Distance Threshold	Minimum Detection Distance Threshold
FD FC FB FA	1A 00	71 01	00 00	0C 00 00 00	00 00 00 00
No -person Delay Time	Status Upload Frequency	Distance Upload Frequency	Response Speed	Frame Tail	
28 00 00 00	0A 00 00 00	0A 00 00 00	0A 00 00 00	04 03 02 01	

2.2.8. Write Trigger Threshold Parameter Command

This command is used to configure the trigger threshold parameters for distance zones 0–15 of the sensor.

Command Code: 0x0072

Command Value: (2 bytes parameter code + 4 bytes parameter value) × N

Return Value: 2 bytes ACK status (0 success, 1 failure)

Sent Data:

(Example: Trigger Thresholds = [50,46,34,32,32,32,32,32,50,46,34,32,32,32,32,32])

Frame Header	Frame Data Length	Command Code	Distance Zone 0 Trigger Threshold	Distance Zone 1 Trigger Threshold	Distance Zone 2 Trigger Threshold	Distance Zone 3 Trigger Threshold
FD FC FB FA	62 00	72 00	00 00 32 00 00 00	01 00 2E 00 00 00	02 00 2E 00 00 00	03 00 20 00 00 00
Distance Zone 4 Trigger Threshold	Distance Zone 5 Trigger Threshold	Distance Zone 6 Trigger Threshold	Distance Zone 7 Trigger Threshold	Distance Zone 8 Trigger Threshold	Distance Zone 9 Trigger Threshold	Distance Zone 10 Trigger Threshold
04 00 20 00 00 00	05 00 20 00 00 00	06 00 20 00 00 00	07 00 20 00 00 00	08 00 32 00 00 00	09 00 2E 00 00 00	0A 00 20 00 00 00
Distance Zone 11 Trigger Threshold	Distance Zone 12 Trigger Threshold	Distance Zone 13 Trigger Threshold	Distance Zone 14 Trigger Threshold	Distance Zone 15 Trigger Threshold	Frame Tail	
0B 00 1E 00 00 00	0C 00 1E 00 00 00	0D 00 1E 00 00 00	0E 00 1E 00 00 00	0F 00 1E 00 00 00	04 03 02 01	

ACK (Success):

Frame Header	Frame Data Length	Command Code	ACK	Frame Tail
FD FC FB FA	04 00	72 01	00 00	04 03 02 01

2.2.9. Read Trigger Threshold Parameter Command

This command is used to read the trigger threshold parameters for distance zones 0–15 of the sensor.

Command Code: 0x0073

Command Value: (2 bytes parameter code) × N

Return Value: (4 bytes parameter value) × N

Sent Data:

Frame Header	Frame Data Length	Command Code	Distance Zone 0 Trigger	Distance Zone 1 Trigger	Distance Zone 2 Trigger	Distance Zone 3 Trigger

			Threshold	Threshold	Threshold	Threshold
FD FC FB FA	22 00	73 00	00 00	01 00	02 00	03 00
Distance Zone 4 Trigger Threshold	Distance Zone 5 Trigger Threshold	Distance Zone 6 Trigger Threshold	Distance Zone 7 Trigger Threshold	Distance Zone 8 Trigger Threshold	Distance Zone 9 Trigger Threshold	Distance Zone 10 Trigger Threshold
04 00	05 00	06 00	07 00	08 00	09 00	0A 00
Distance Zone 11 Trigger Threshold	Distance Zone 12 Trigger Threshold	Distance Zone 13 Trigger Threshold	Distance Zone 14 Trigger Threshold	Distance Zone 15 Trigger Threshold	Frame Tail	
0B 00	0C 00	0D 00	0E 00	0F 00	04 03 02 01	

ACK (Success) : (Example: Trigger Thresholds=[50, 46, 34, 32, 32, 32, 32, 32, 50, 46, 34, 32, 32, 32, 32, 32])

Frame Header	Frame Data Length	Command Code	ACK	Distance Zone 0 Trigger Threshold	Distance Zone 1 Trigger Threshold	Distance Zone 2 Trigger Threshold
FD FC FB FA	44 00	73 01	00 00	32 00 00 00	2E 00 00 00	22 00 00 00
Distance Zone 3 Trigger Threshold	Distance Zone 4 Trigger Threshold	Distance Zone 5 Trigger Threshold	Distance Zone 6 Trigger Threshold	Distance Zone 7 Trigger Threshold	Distance Zone 8 Trigger Threshold	Distance Zone 9 Trigger Threshold
20 00 00 00	20 00 00 00	20 00 00 00	20 00 00 00	20 00 00 00	32 00 00 00	2E 00 00 00
Distance Zone 10 Trigger Threshold	Distance Zone 11 Trigger Threshold	Distance Zone 12 Trigger Threshold	Distance Zone 13 Trigger Threshold	Distance Zone 14 Trigger Threshold	Distance Zone 15 Trigger Threshold	Frame Tail
20 00 00 00	1E 00 00 00	1E 00 00 00	1E 00 00 00	1E 00 00 00	1E 00 00 00	04 03 02 01

2.2.10. Write Hold Threshold Parameter Command

This command is used to write the hold threshold parameters for distance zones 0–15 of the sensor.

Command Code: 0x0076

Command Value: (2 bytes parameter code + 4 bytes parameter value) × N

Return Value: 2 bytes ACK status (0 success, 1 failure)

Sent Data: (Example: Hold Thresholds = [15, 15, 15, 15, 15, 15, 15, 15, 15, 09, 09, 09, 09, 09, 09, 09, 09])

Frame Header	Frame Data Length	Command Code	Distance Zone 0 Hold Threshold	Distance Zone 1 Hold Threshold	Distance Zone 2 Hold Threshold	Distance Zone 3 Hold Threshold
FD FC FB FA	62 00	76 00	00 00 0F 00 00 00	01 00 0F 00 00 00	02 00 0F 00 00 00	03 00 0F 00 00 00

Distance Zone 4 Hold Threshold	Distance Zone 5 Hold Threshold	Distance Zone 6 Hold Threshold	Distance Zone 7 Hold Threshold	Distance Zone 8 Hold Threshold	Distance Zone 9 Hold Threshold	Distance Zone 10 Hold Threshold
04 00 0F 00 00 00	05 00 0F 00 00 00	06 00 0F 00 00 00	07 00 0F 00 00 00	08 00 09 00 00 00	09 00 09 00 00 00	0A 00 09 00 00 00
Distance Zone 11 Hold Threshold	Distance Zone 12 Hold Threshold	Distance Zone 13 Hold Threshold	Distance Zone 14 Hold Threshold	Distance Zone 15 Hold Threshold	Frame Tail	
0B 00 09 00 00 00	0C 00 09 00 00 00	0D 00 09 00 00 00	0E 00 09 00 00 00	0F 00 09 00 00 00	04 03 02 01	

ACK (Success):

Frame Header	Frame Data Length	Command Code	ACK	Frame Tail
FD FC FB FA	04 00	76 01	00 00	04 03 02 01

2.2.11. Read Hold Threshold Parameter Command

This command is used to read the hold threshold parameters for distance zones 0–15 of the sensor.

Command Code: 0x0077

Command Value: (2 bytes parameter code) × N

Return Value: (4 bytes parameter value) × N

Sent Data:

Frame Header	Frame Data Length	Command Code	Distance Zone 0 Hold Threshold	Distance Zone 1 Hold Threshold	Distance Zone 2 Hold Threshold	Distance Zone 3 Hold Threshold
FDFCFBFA	22 00	77 00	00 00	01 00	02 00	03 00
Distance Zone 4 Hold Threshold	Distance Zone 5 Hold Threshold	Distance Zone 6 Hold Threshold	Distance Zone 7 Hold Threshold	Distance Zone 8 Hold Threshold	Distance Zone 9 Hold Threshold	Distance Zone 10 Hold Threshold
04 00	05 00	06 00	07 00	08 00	09 00	0A 00
Distance Zone 11 Hold Threshold	Distance Zone 12 Hold Threshold	Distance Zone 13 Hold Threshold	Distance Zone 14 Hold Threshold	Distance Zone 15 Hold Threshold	Frame Tail	
0B 00	0C 00	0D 00	0E 00	0F 00	04 03 02 01	

ACK (Success): (Example: Hold Thresholds = [15, 15, 15, 15, 15, 15, 15, 15, 09, 09, 09, 09, 09, 09, 09, 09])

Frame Header	Frame Data Length	Command Code	ACK	Distance Zone 0 Hold Threshold	Distance Zone 1 Hold Threshold	Distance Zone 2 Hold Threshold
---------------------	--------------------------	---------------------	------------	---------------------------------------	---------------------------------------	---------------------------------------

FD FC FB FA	44 00	77 01	00 00	0F 00 00 00	0F 00 00 00	0F 00 00 00
Distance Zone 3 Hold Threshold	Distance Zone 4 Hold Threshold	Distance Zone 5 Hold Threshold	Distance Zone 6 Hold Threshold	Distance Zone 7 Hold Threshold	Distance Zone 8 Hold Threshold	Distance Zone 9 Hold Threshold
0F 00 00 00	0F 00 00 00	0F 00 00 00	0F 00 00 00	0F 00 00 00	09 00 00 00	09 00 00 00
Distance Zone 10 Hold Threshold	Distance Zone 11 Hold Threshold	Distance Zone 12 Hold Threshold	Distance Zone 13 Hold Threshold	Distance Zone 14 Hold Threshold	Distance Zone 15 Hold Threshold	Frame Tail
09 00 00 00	09 00 00 00	09 00 00 00	09 00 00 00	09 00 00 00	09 00 00 00	04 03 02 01

2.2.12. Automatic Threshold Generation Command

This command is used to enable automatic threshold generation.

Command Code: 0x0009

Command Data: (2 bytes parameter value) × 3, where the parameters are sequentially: motion trigger threshold generation coefficient, hold threshold generation coefficient, and scan duration.

Return Value: 4 bytes parameter value

Sent Data:

(Motion trigger threshold generation coefficient: 2 dB; Hold threshold generation coefficient: 1 dB; Scan duration: 120 seconds)

Frame Header	Frame Data Length	Command Code	Motion Trigger Threshold Generation Coefficient	Hold Threshold Generation Coefficient	Scan Duration	Frame Tail
FDFCFBFA	08 00	09 00	02 00	01 00	78 00	04 03 02 01

Radar ACK (Success):

Frame Header	Frame Data Length	Parameter Value	Frame Tail
FDFCFBFA	04 00	09 01 00 00	04 03 02 01

2.2.13. Query Automatic Threshold Generation Progress Command

This command is used to query the progress of automatic threshold generation.

Command Code: 0x00FE

Return Value: 4-byte parameter value

Sent Data:

Frame Header	Frame Data Length	Command Code	Frame Tail
FDFCFBFA	02 00	FE 00	04 03 02 01

Radar ACK (Success):

Frame Header	Frame Data Length	Parameter Value	Frame Tail
FDFCFBFA	04 00	FE 01 00 00	04 03 02 01

2.3. Radar Command Configuration Method

2.3.1. Radar Command Configuration Steps

The process for setting parameters:

1. The host machine sends the “Enable Configuration Command” to put the MCU into command mode. At this time, the MCU does not perform human body detection and waits only for commands from the host machine.
2. The host machine sends parameter configuration, parameter reading, and other related commands.
3. The host machine sends the “End Configuration Command”. At this time, the MCU enters normal operating mode and begins human body detection.

2.3.2. Radar Configuration Precautions

Notes:

1. The maximum data length of a single serial command shall not exceed 64 bytes (this size may vary depending on actual conditions and different platforms; when the host sends a command, the response from the slave device includes the serial communication buffer size). Therefore, when reading or writing multiple registers, if the data exceeds 64 bytes, it must be split into multiple commands.
2. Byte order: Little-endian
3. Since the serial port defaults to outputting radar waveform data, it is necessary to switch to command mode before sending commands. The typical procedure involves three steps:
 - (1) Send the “Enter Command Mode” command (as the chip may still be outputting data, the data received via the serial port may include waveform data, so the response result is ignored).
 - (2) Clear the serial port buffer data (typically delay for 100ms to ensure all serial port data is cleared).
 - (3) Send the “Enter Command Mode” command again, and analyze the response result.

After exiting command mode, send the “Exit Command Mode” command to enable waveform data transmission.

4. It is recommended that custom command IDs be defined within the range of 0x0060–0x00A0.

3.Contact Information

[Official Website](#)

[Official Forum](#)

[Development DOCS](#)

[LinkedIn](#)

[Tmall Store](#)

[Taobao Store](#)

[Alibaba Store](#)

[Technical Support: support@aithinker.com](mailto:support@aithinker.com)

[Domestic Business Cooperation: sales@aithinker.com](mailto:sales@aithinker.com)

[Overseas Business Cooperation: overseas@aithinker.com](mailto:overseas@aithinker.com)

Company Address: Room 403, 408-410, Building C, Huafeng Smart Innovation Port, Gushu, Xixiang,
Bao'an District, Shenzhen, Guangdong, China

Contact Hotline: 0755-29162996



WeChat Mini Program



WeChat Official Account

Disclaimer and Copyright Notice

The information in this document, including referenced URLs, is subject to change without notice.

The document is provided “as is” without warranty of any kind, express or implied, including but not limited to the warranties of merchantability, fitness for a particular purpose, or non-infringement. Furthermore, no warranty is given regarding proposals, specifications, or samples mentioned elsewhere. The publisher bears no responsibility, including for any infringement of patent rights arising from the use of information contained herein. This document does not grant, expressly or impliedly, by estoppel or otherwise, any license to intellectual property rights.

All test data presented herein are obtained from Ai-Thinker laboratories. Actual results may vary slightly.

All trade names, trademarks, and registered trademarks mentioned are the property of their respective owners.

Shenzhen Ai-Thinker Technology Co., Ltd. reserves the final right of interpretation of this document.

Notice

This manual may be updated due to product version upgrades or other reasons.

Shenzhen Ai-Thinker Technology Co., Ltd. reserves the right to modify the content of this manual without prior notice or announcement.

This manual is intended as a usage guide only. While Shenzhen Ai-Thinker Technology Co., Ltd. strives to provide accurate information, it does not guarantee that the content is entirely free of errors. All statements, information, and recommendations in this manual do not constitute any express or implied warranty.

Statement

Shenzhen Ai-Thinker Technology Co., Ltd. (hereinafter “Ai-Thinker”) may provide all technical and reliability data (including datasheets), design resources (including reference designs), application or other design advice, web tools, security information, and other resources (collectively referred to as “these Resources”) on an “as is” basis, without warranty of any kind, express or implied, including but not limited to warranties of merchantability, fitness for a particular purpose, or non-infringement of any third-party intellectual property rights. Ai-Thinker specifically disclaims any liability for losses, whether direct or consequential, arising from the application or use of any Ai-Thinker products or circuits.

Ai-Thinker reserves the right to modify the content of this document (including but not limited to specifications and product descriptions) and any related products without prior notice. This document automatically supersedes and replaces all previous versions of the same document number.

These Resources are intended for use by skilled developers designing with Ai-Thinker products. You are solely responsible for: (1) Selecting the appropriate Ai-Thinker products for your application; (2) Designing, validating, and operating your application and product throughout its life cycle; (3) Ensuring your application complies with all applicable standards, laws, and any other functional safety, information security, regulatory, or other requirements.

Ai-Thinker may authorize you to use these Resources solely for developing applications incorporating the Ai-Thinker products described herein. No part of these Resources may be copied, reproduced, or distributed in any form without prior written permission from Ai-Thinker. You are not permitted to use any other intellectual property of Ai-Thinker or any third party. You shall fully indemnify Ai-Thinker and its representatives against any claims, damages, costs, losses, or liabilities arising from your use of these Resources, for which Ai-Thinker assumes no liability.

Ai-Thinker’s products are supplied under Ai-Thinker’s general sales terms and conditions or other applicable terms accompanying the products. The provision of these Resources does not expand or otherwise alter the warranties or warranty disclaimers applicable to the product as delivered.