

# Ai-M64P-32S-Kit Specification

Version V1.0.1

Copyright ©2026

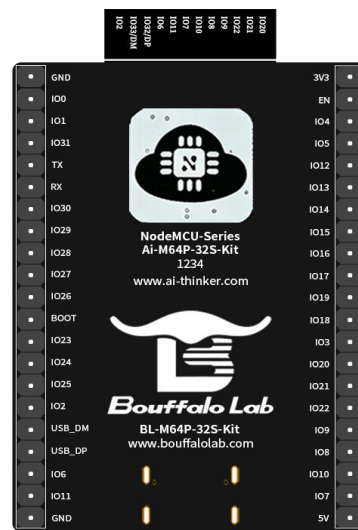
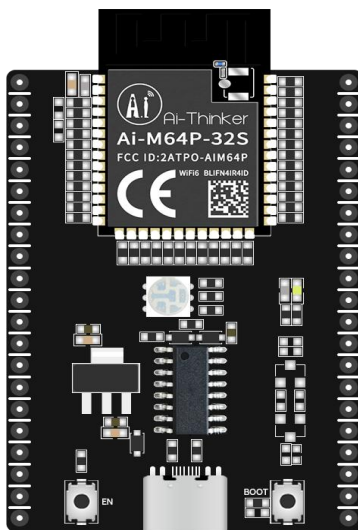

## Document Revision History

Version	Date	Description of Changes	Authored by	Approved by
V1.0.0	2026-06-01	First edition	Qian Zekai	Xu Hong
V1.0.1	2026-06-10	Corrected the positions of warm and cold LEDs	Qian Zekai	Xu Hong

## Contents

1 Product Overview .....	5
1.1 Features .....	6
1.2 Applications .....	7
2 Main Parameters .....	8
2.1 Power Supply Options .....	8
3 Electrical Characteristics .....	9
3.1 Recommended Operating Conditions .....	9
3.2 I/O DC Electrical Characteristics .....	9
3.3 Electrostatic Discharge .....	9
3.4 Wi-Fi RF Performance .....	10
3.5 BLE RF Performance .....	11
3.6 Power Consumption .....	12
4 Mechanical Specifications .....	13
4.1 Development Board Dimensions .....	13
5 LED Indicator and Button Description .....	14
6 Pin Definition .....	15
7 Schematic Diagram .....	19
8 Packaging Information .....	20
9 Contact Information .....	20
Disclaimer and Copyright Notice .....	21
Notice .....	21
Statement .....	22

## List of Figures

Figure 1	Main Chip Architecture Diagram .....	5
Figure 2	ESD Protection Symbol .....	9
Figure 3	Dimension Diagram .....	13
Figure 4	LED Indicator and Button Location .....	14
Figure 5	Pin Diagram (Top View) .....	15
Figure 6	Pin Diagram (Bottom View) .....	15
Figure 7	Schematic Diagram .....	19

## List of Tables

Table 1	Main Parameter Specification .....	8
Table 2	Recommended Operating Conditions .....	9
Table 3	I/O DC Electrical Characteristics .....	9
Table 4	Wi-Fi RF Performance .....	10
Table 5	BLE RF Performance .....	11
Table 6	Power Consumption .....	12
Table 7	LED Indicator Status and Button Functions .....	14
Table 8	Pin Function Definition .....	15
Table 9	Packaging Information .....	20

# 1 Product Overview

The Ai-M64P-32S-Kit is a development board developed based on the Ai-M64P-32S module. The Ai-M64P-32S is a standardized wireless module based on the Bouffalo Lab BL616CL RF chip, specifically designed for ultra-low power, high-performance, and high-security IoT scenarios. The module fully retains the chip-level RF performance and full-function peripherals, and it undergoes rigorous RF matching and reliability verification with plug-and-play capability, significantly reducing the development barriers and mass-production risks of end products. The product features five core features: strong signal performance, low power consumption, high integration, security and reliability, and ultra-compact package, while also supporting backward compatibility.

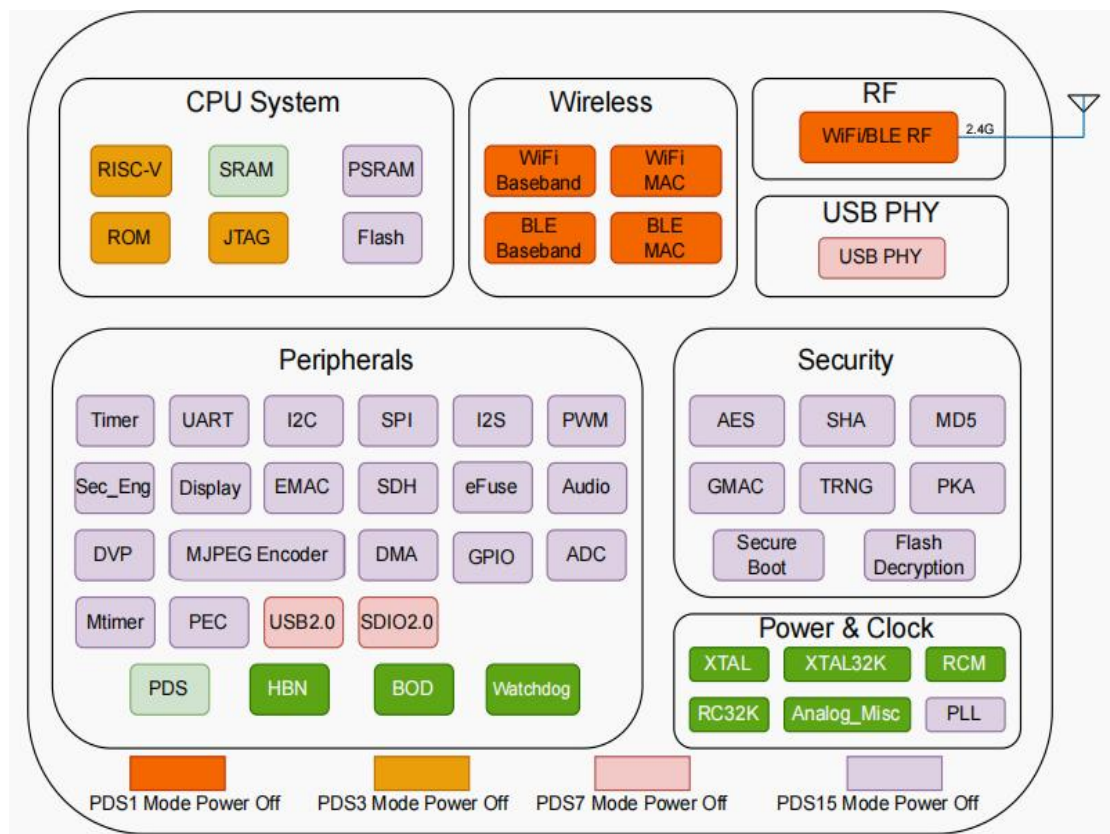

**Figure 1 Main Chip Architecture Diagram**

## 1.1 Features

- **Wi-Fi 6**
  - ✧ Supports IEEE 802.11b/g/n/ax, 20MHz bandwidth, 1T1R
  - ✧ Fully supports OFDMA, TWT, LDPC, STBC, Beamformee, and RX diversity, enabling more stable, longer-range, and more power-efficient concurrent connections for multiple devices
  - ✧ Receiver sensitivity reaches -99dBm@1Mbps, providing superior wall penetration and long-range coverage compared with similar products
  - ✧ Transmit power reaches 23dBm@1Mbps, providing sufficient link margin and no disconnection in weak network environments
- **BLE 5.3 Long Range and Low Latency**
  - ✧ Supports BLE 5.3 with multiple data rates: 2Mbps, 1Mbps, 500kbps, and 125kbps
  - ✧ Receiver sensitivity reaches -99dBm@125kbps
  - ✧ Supports multi-connection, extended advertising, AOI/AOD, compatible with gateways and sensor nodes
- **Wi-Fi/BLE Coexistence**
  - ✧ Built-in coexistence engine at chip level. No external switch is required, and dual-mode TDD operation is supported without interference
  - ✧ Supports BLE-assisted Wi-Fi fast connection, with over 50% faster provisioning speed
- **High Computing Performance and Large Memory**
  - ✧ 32-bit RISC-V CPU, up to 320MHz, with FPU and DSP, supporting edge computing
  - ✧ Built-in 388KB SRAM, 224KB OCRAM, 160KB WRAM, 4KB HBN RAM, optional 2/4/8MB Flash and 4/8MB PSRAM
- **Full-Function Interfaces, One Module Replacing Multiple Chips**
  - ✧ Integrated USB2.0 HS, EMAC 10/100M, DVP camera, DBI display, MJPEG codec
  - ✧ Rich peripherals: 3\*UART, 2\*I2C, 2\*SPI, 1\*I2S, 1\*PWM (4 channels), 1\*16-bit GPADC (12 channels), and 1\*Touch interface
- **Industrial-grade Low Power Consumption and Security**
  - ✧ Supports PDS (Power Down Sleep) and HBN (Hibernate) modes. Sleep current is at the  $\mu$ A level, helping extend battery life
  - ✧ Secure boot, firmware encrypt and sign, TrustZone, full hardware encryption with AES/SHA/PKA/TRNG, protecting against cracking and tampering
- **High Reliability and Easy Mass Production**
  - ✧ Normal operating temperature: -40–85°C (customizable to -40–105°C )
  - ✧ Pre-certified RF parameters shorten the certification cycle, plug-and-play

Note: For features not listed in this document, please refer to the BL616CL chip datasheet.

## 1.2 Applications

- Audio and Video Multimedia
- Internet of Things (IoT)
- Mobile Devices
- Smart Home
- Central Control Devices

## 2 Main Parameters

**Table 1 Main Parameter Specification**

<b>Model</b>	Ai-M64P-32S-Kit
<b>Package</b>	DIP-42
<b>Dimensions</b>	53.5*38.1 (mm)
<b>Antenna Type</b>	On-board antenna
<b>Frequency Range</b>	2400–2483.5 MHz
<b>Operating Temperature</b>	-40–85°C
<b>Storage Conditions</b>	-40–125°C, <90% RH
<b>Power Supply Range</b>	Supply voltage: 3.3V or 5V; supply current>500mA
<b>Available I/Os</b>	37 (default)
<b>UART Baud Rate</b>	115200bps (default)

### 2.1 Power Supply Options

The Ai-M64P-32S-Kit supports three power supply options:

- Type-C interface (recommended)
- 3V3 and GND pin header
- 5V and GND pin header

### 3 Electrical Characteristics

#### 3.1 Recommended Operating Conditions

**Table 2 Recommended Operating Conditions**

Parameter	Condition	Min	Typ	Max	Unit
Interface Power Supply	Type-C	4.5	5	5.3	V
Pin Header Power Supply	3V3	2.97	3.3	3.63	V
	5V	4.5	5	5.3	V

#### 3.2 I/O DC Electrical Characteristics

**Table 3 I/O DC Electrical Characteristics**

Symbol	Parameter	Min	Typ	Max	Unit
VIH	High-level Input Voltage	2	-	-	V
VIL	Low-level Input Voltage	-	-	0.8	V
VOH	High-level Output Voltage	-	0.9 * VCC	-	V
VOL	Low-level Output Voltage	-	0.1 * VCC	-	V

#### 3.3 Electrostatic Discharge

The Ai-M64P-32S-Kit is an ESD-sensitive device and requires special precautions during handling.



**Figure 2 ESD Protection Symbol**

### 3.4 Wi-Fi RF Performance

**Table 4 Wi-Fi RF Performance**

Description	Typ			Unit
Frequency Range	2400–2483.5			MHz
<b>Output Power</b>				
Mode	Min	Typ	Max	Unit
802.11b, 11Mbps	-	19	23	dBm
802.11g, 54Mbps	-	18	20	dBm
802.11n, HT20 (MCS7)	-	18	19	dBm
802.11ax, HE20 (MCS9)	-	16	17	dBm
<b>Receiver Sensitivity</b>				
Mode	Min	Typ	Max	Unit
802.11b, 1Mbps	-99	-	-	dBm
802.11b, 11Mbps	-90	-	-	dBm
802.11g, 6Mbps	-93	-	-	dBm
802.11g, 54Mbps	-78	-	-	dBm
802.11n, HT20 (MCS7)	-76	-	-	dBm
802.11ax, HE20 (MCS9)	-69	-	-	dBm

### 3.5 BLE RF Performance

**Table 5 BLE RF Performance**

Description	Typ			Unit
Frequency Range	2400–2483.5			MHz
<b>Output Power</b>				
Data Rate Mode	Min	Typ	Max	Unit
1Mbps	-	10	15	dBm
2Mbps	-	10	15	dBm
<b>Receiver Sensitivity</b>				
Data Rate Mode	Min	Typ	Max	Unit
1Mbps Sensitivity @ 30.8% PER	-99	-	-	dBm
2Mbps Sensitivity @ 30.8% PER	-97	-	-	dBm

### 3.6 Power Consumption

The following power consumption data are measured based on a 3.3V power supply and an ambient temperature of 25°C.

- The POUT power for all transmit modes is measured at the antenna interface.
- All transmission data are measured at 100% duty cycle in continuous transmit mode.

**Table 6 Power Consumption**

Mode	Min	Avg	Max	Unit
TX 802.11b, 11Mbps, POUT = +23dBm	-	435	-	mA
TX 802.11g, 54Mbps, POUT = +20dBm	-	352	-	mA
TX 802.11n, MCS7, POUT = +19dBm	-	338	-	mA
TX 802.11ax, MCS9, POUT = +17dBm	-	290	-	mA
RX 802.11b, Packet Length 1500 bytes	-	84.5	-	mA
RX 802.11g, Packet Length 1500 bytes	-	84.5	-	mA
RX 802.11n, Packet Length 1500 bytes	-	84.5	-	mA
RX 802.11ax, Packet Length 1500 bytes	-	84.5	-	mA
PDS (Tickless 3), Wi-Fi Disconnected	-	45	-	μA
PDS (Tickless 3), Wi-Fi Connected	-	256	-	μA
PDS (Tickless 10), Wi-Fi Disconnected	-	45	-	μA
PDS (Tickless 10), Wi-Fi Connected	-	90	-	μA
HBN Mode	-	5	-	μA

## 4 Mechanical Specifications

### 4.1 Development Board Dimensions

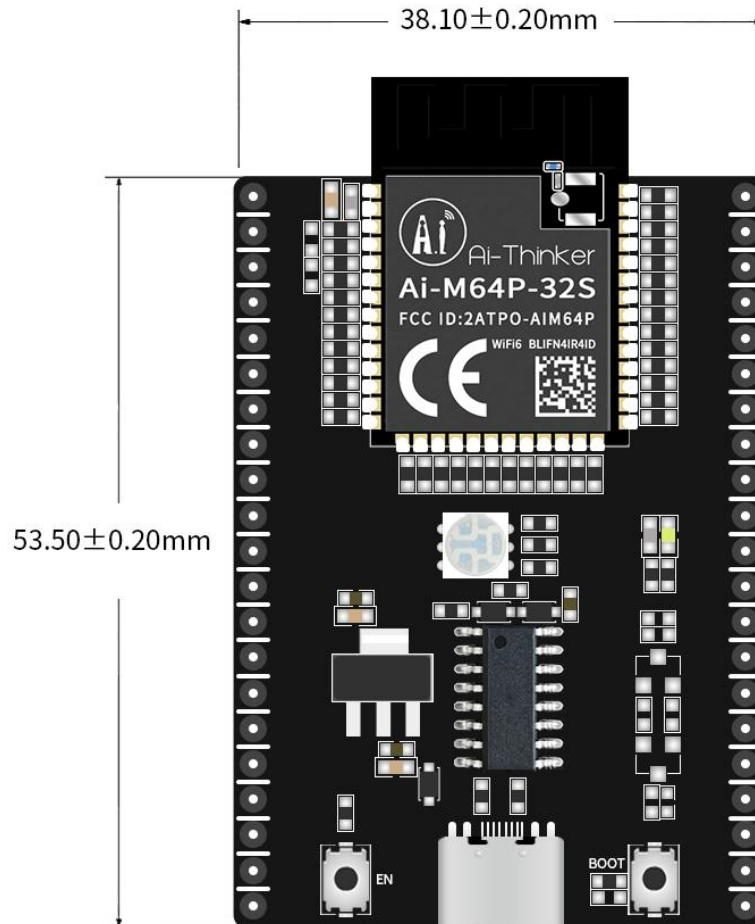
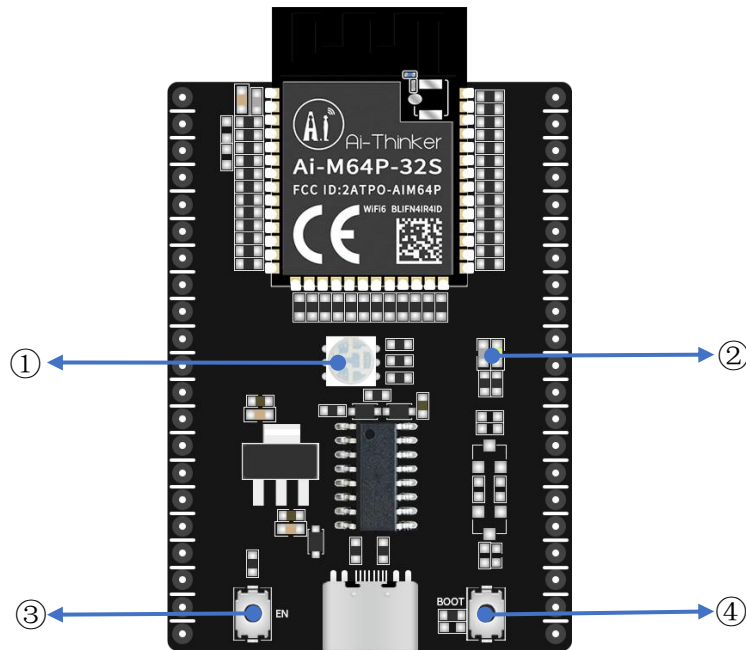

Figure 3 Dimension Diagram

## 5 LED Indicator and Button Description



**Figure 4 LED Indicator and Button Location**

**Table 7 LED Indicator Status and Button Functions**

①	RGB LED (The red LED is connected to IO14, the green LED is connected to IO15, and the blue LED is connected to IO16. Active high.)
②	LED lights. (The left warm LED is connected to IO28, and the right cold LED is connected to IO27. Active high.)
③	Reset button
④	Flash button. When flashing firmware, press and hold the flash button first, then briefly press the reset button at the same time.



2	EN	Default chip enable pin, active-high
3	IO4	GPIO4/SPI0_SS/SPI1_SS/I2S_BCLK/I2C_SCL/UART_SIG4/ADC_CH4/PWM0_CH0P/PWM0_CH2P/DBI_TypeC_SDA/JTAG_TMS (Default available. This IO is shared with the module's internal 32.768kHz crystal input pin. If the module is customized with an internal mounted 32.768kHz crystal, this IO is NC.)
4	IO5	GPIO5/SPI0_SCLK/SPI1_SCLK/I2S_FS/I2C_SDA/UART_SIG5/ADC_CH5/PWM0_CH1P/PWM0_CH2N/DBI_TypeC_DCn/JTAG_TCK (Default available. This IO is shared with the module's internal 32.768kHz crystal output pin. If the module is customized with an internal mounted 32.768kHz crystal, this IO is NC.)
5	IO12	GPIO12/SPI0_SS/SPI1_SS/I2S_BCLK/I2C_SCL/UART_SIG0/RMII_MDI_O/CAM_DAT0/ADC_CH8/PWM0_CH0P/PWM0_CH2P/DBI_TypeB_DB0/DBI_TypeC_SDA/DISP_QSPI_SCL/AUPWM_P/JTAG_TMS
6	IO13	GPIO13/SPI0_SCLK/SPI1_SCLK/I2S_FS/I2C_SDA/UART_SIG1/RMII_MDC/CAM_DAT1/ADC_CH9/PWM0_CH1P/PWM0_CH2N/DBI_TypeB_DB1/DBI_TypeC_DCn/DISP_QSPI_CSn/AUPWM_N/JTAG_TCK
7	IO14	GPIO14/SPI0_MISO/SPI1_MISO/I2S_DI/I2S_RCLK_O/I2C_SCL/UART_SIG2/PDM_CLK/RMII_TX_EN/CAM_DAT2/PWM0_CH2P/PWM0_CH3P/DBI_TypeB_DB2/DBI_TypeC_SCL/DISP_QSPI_SDA0/JTAG_TDO
8	IO15	GPIO15/SPI0_MOSI/SPI1_MOSI/I2S_DO/I2S_RCLK_O/I2C_SDA/UART_SIG3/PDM_IN/RMII_TXD[1]/CAM_DAT3/PWM0_CH3P/PWM0_CH3N/DBI_TypeB_DB3/DBI_TypeC_CSn/DISP_QSPI_SDA1/JTAG_TDI
9	IO16	GPIO16/SPI0_SS/SPI1_SS/I2S_BCLK/I2C_SCL/UART_SIG4/RMII_TXD[0]/CAM_DAT4/PWM0_CH0P/DBI_TypeB_DB4/DBI_TypeC_SDA/DISP_QSPI_SDA2/JTAG_TMS
10	IO17	GPIO17/SPI0_SCLK/SPI1_SCLK/I2S_FS/I2C_SDA/UART_SIG5/RMII_REF_CLK/CAM_DAT5/PWM0_CH1P/PWM0_CH0N/DBI_TypeB_DB5/DBI_TypeC_DCn/DISP_QSPI_SDA3/JTAG_TCK
11	IO19	GPIO19/SPI0_MOSI/SPI1_MOSI/I2S_DO/I2S_RCLK_O/I2C_SDA/UART_SIG7/RMII_RXD[0]/CAM_DAT7/PWM0_CH3P/PWM0_CH1N/DBI_TypeB_DB7/DBI_TypeC_CSn/DISP_QSPI_CSn/AUPWM_N/JTAG_TDI
12	IO18	GPIO18/SPI0_MISO/SPI1_MISO/I2S_DI/I2S_RCLK_O/I2C_SCL/UART_SIG6/RMII_RXD[1]/CAM_DAT6/PWM0_CH2P/PWM0_CH1P/DBI_TypeB_DB6/DBI_TypeC_SCL/DISP_QSPI_SCL/AUPWM_P/JTAG_TDO
13	IO3	GPIO3/SPI0_MOSI/SPI1_MOSI/I2S_DO/I2S_RCLK_O/I2C_SDA/UART_SIG3/ADC_CH3/PWM0_CH3P/PWM0_CH1N/DBI_TypeB_DCn/DBI_TypeC_CSn/JTAG_TDI (Default unavailable. This IO is internally connected to the module DC-DC for low-power use. If low power is not required and this IO needs to be used, please contact Ai-Thinker for customization.)
14	IO20	GPIO20/SPI0_SS/SPI1_SS/I2S_BCLK/I2C_SCL/UART_SIG8/PDM_CLK/RMII_RX_DV/CAM_VSYNC/PWM0_CH0P/PWM0_CH2P/DBI_TypeC_SDA/DISP_QSPI_SDA0/JTAG_TMS
15	IO21	GPIO21/SPI0_SCLK/SPI1_SCLK/I2S_FS/I2C_SDA/UART_SIG9/PDM_IN/CAM_CLK/PWM0_CH1P/PWM0_CH2N/DBI_TypeC_DCn/DISP_QSPI

		_SDA1/JTAG_TCK
16	IO22	GPIO22/SPI0_MISO/SPI1_MISO/I2S_DI/I2S_RCLK_O/I2C_SCL/UART_SIG10/CAM_HSYNC/PWM0_CH2P/PWM0_CH3P/DBI_TypeC_SCL/DISP_QSPI_SDA2/JTAG_TDO
17	IO9	GPIO9/SPI0_SCLK/SPI1_SCLK/I2S_FS/I2C_SDA/UART_SIG9/SF2_D0/SDIO_CLK/PWM0_CH1P/PWM0_CH0N/DBI_TypeC_DCn/DISP_QSPI_SDA1/JTAG_TCK (Default available. This IO is shared with the module's internal Flash pin. If the module is customized with internal mounted Flash, this IO is NC.)
18	IO8	GPIO8/SPI0_SS/SPI1_SS/I2S_BCLK/I2C_SCL/UART_SIG8/SF2_D2/SDIO_CMD/PWM0_CH0P/DBI_TypeC_SDA/DISP_QSPI_SDA0/JTAG_TMS (Default available. This IO is shared with the module's internal Flash pin. If the module is customized with internal mounted Flash, this IO is NC.)
19	IO10	GPIO10/SPI0_MISO/SPI1_MISO/I2S_DI/I2S_RCLK_O/I2C_SCL/UART_SIG10/SF2_CLK/SDIO_DAT0/PWM0_CH2P/PWM0_CH1P/DBI_TypeC_SCL/DISP_QSPI_SDA2/JTAG_TDO (Default available. This IO is shared with the module's internal Flash pin. If the module is customized with internal mounted Flash, this IO is NC.)
20	IO7	GPIO7/SPI0_MOSI/SPI1_MOSI/I2S_DO/I2S_RCLK_O/I2C_SDA/UART_SIG7/SF2_D1/ADC_CH7/SDIO_DAT3/PWM0_CH3P/PWM0_CH3N/DBI_TypeC_CSn/DISP_QSPI_CSn/JTAG_TDI (Default available. This IO is shared with the module's internal Flash pin. If the module is customized with internal mounted Flash, this IO is NC.)
21	5V	5V power supply; supply current recommended >500mA
22	GND	Ground
23	IO0	GPIO0/SPI0_SS/SPI1_SS/I2S_BCLK/I2C_SCL/UART_SIG0/ADC_CH0/PWM0_CH0P/DBI_TypeB_CSn/DBI_TypeC_SDA/JTAG_TMS
24	IO1	GPIO1/SPI0_SCLK/SPI1_SCLK/I2S_FS/I2C_SDA/UART_SIG1/ADC_CH1/PWM0_CH1P/PWM0_CH0N/DBI_TypeB_RDn/DBI_TypeC_DCn/JTAG_TCK
25	IO31	GPIO31/SPI0_MOSI/SPI1_MOSI/I2S_DO/I2S_RCLK_O/I2C_SDA/UART_SIG7/RMII_RX_DV/CAM_DAT7/PWM0_CH3P/PWM0_CH3N/DBI_TypeB_DB7/DBI_TypeC_CSn/AUPWM_N/JTAG_TDI
26	TX	GPIO34/SPI0_MISO/SPI1_MISO/I2S_DI/I2S_RCLK_O/I2C_SCL/UART_SIG10/PWM0_CH2P/PWM0_CH1P/DBI_TypeC_SCL/JTAG_TDO
27	RX	GPIO35/SPI0_MOSI/SPI1_MOSI/I2S_DO/I2S_RCLK_O/I2C_SDA/UART_SIG11/PWM0_CH3P/PWM0_CH1N/DBI_TypeC_CSn/JTAG_TDI
28	IO30	GPIO30/SPI0_MISO/SPI1_MISO/I2S_DI/I2S_RCLK_O/I2C_SCL/UART_SIG6/RMII_RXD[0]/CAM_DAT6/PWM0_CH2P/PWM0_CH3P/DBI_TypeB_DB6/DBI_TypeC_SCL/AUPWM_P/JTAG_TDO
29	IO29	GPIO29/SPI0_SCLK/SPI1_SCLK/I2S_FS/I2C_SDA/UART_SIG5/SF3_CS/RMII_RXD[1]/CAM_DAT3/PWM0_CH1P/PWM0_CH2N/DBI_TypeB_DB5/DBI_TypeC_DCn/DISP_QSPI_SDA3/JTAG_TCK
30	IO28	GPIO28/SPI0_SS/SPI1_SS/I2S_BCLK/I2C_SCL/UART_SIG4/SF3_D1/RM

		II_REF_CLK/CAM_DAT2/PWM0_CH0P/PWM0_CH2P/DBI_TypeB_DB4/DBI_TypeC_SDA/DISP_QSPI_SDA2/JTAG_TMS
31	IO27	GPIO27/SPI0_MOSI/SPI1_MOSI/I2S_DO/I2S_RCLK_O/I2C_SDA/UART_SIG3/SF3_D2/PDM_IN/RMII_TXD[0]/CAM_DAT1/PWM0_CH3P/PWM0_CH1N/DBI_TypeB_DB3/DBI_TypeC_CSn/DISP_QSPI_SDA1/JTAG_TDI
32	IO26	GPIO26/SPI0_MISO/SPI1_MISO/I2S_DI/I2S_RCLK_O/I2C_SCL/UART_SIG2/SF3_D0/PDM_CLK/RMII_TXD[1]/CAM_DAT0/PWM0_CH2P/PWM0_CH1P/DBI_TypeB_DB2/DBI_TypeC_SCL/DISP_QSPI_SDA0/JTAG_TDO
33	BOOT	BOOT: NC by default. If required, please contact the business representative for control. GPIO36/SPI0_SS/SPI1_SS/I2S_BCLK/I2C_SCL/UART_SIG0/PWM0_CH0P/PWM0_CH2P/DBI_TypeB_DCn/JTAG_TMS
34	IO23	GPIO23/SPI0_MOSI/SPI1_MOSI/I2S_DO/I2S_RCLK_O/I2C_SDA/UART_SIG11/RMII_MDIO/CAM_VSYNC/SWGPIO[23]/PWM0_CH3P/PWM0_CH3N/DBI_TypeC_CSn/DISP_QSPI_SDA3/JTAG_TDI
35	IO24	GPIO24/SPI0_SS/SPI1_SS/I2S_BCLK/I2C_SCL/UART_SIG0/SF3_D3/RMII_MDC/CAM_DAT4/PWM0_CH0P/DBI_TypeB_DB0/DBI_TypeC_SDA/DISP_QSPI_SCL/AUPWM_P/JTAG_TMS
36	IO25	GPIO25/SPI0_SCLK/SPI1_SCLK/I2S_FS/I2C_SDA/UART_SIG1/SF3_CLK/RMII_TX_EN/CAM_DAT5/PWM0_CH1P/PWM0_CH0N/DBI_TypeB_DB1/DBI_TypeC_DCn/DISP_QSPI_CSn/AUPWM_N/JTAG_TCK
37	IO2	GPIO2/SPI0_MISO/SPI1_MISO/I2S_DI/I2S_RCLK_O/I2C_SCL/UART_SIG2/ADC_CH2/PWM0_CH2P/PWM0_CH1P/DBI_TypeB_WRn/DBI_TypeC_SCL/JTAG_TDO (Default unavailable. This IO is internally connected to the module DC-DC for low-power use. If low power is not required and this IO needs to be used, please contact Ai-Thinker for customization.)
38	IO33/DM	USB_DM/GPIO33/SPI0_SCLK/SPI1_SCLK/I2S_FS/I2C_SDA/UART_SIG9/PDM_IN/ADC_CH11/PWM0_CH1P/PWM0_CH0N/DBI_TypeC_DCn/JTAG_TCK
39	IO32/DP	USB_DP/GPIO32/SPI0_SS/SPI1_SS/I2S_BCLK/I2C_SCL/UART_SIG8/PDM_CLK/ADC_CH10/PWM0_CH0P/DBI_TypeC_SDA/JTAG_TMS
40	IO6	GPIO6/SPI0_MISO/SPI1_MISO/I2S_DI/I2S_RCLK_O/I2C_SCL/UART_SIG6/SF2_CS/ADC_CH6/SDIO_DAT2/PWM0_CH2P/PWM0_CH3P/DBI_TypeC_SCL/DISP_QSPI_SCL/JTAG_TDO
41	IO11	GPIO11/SPI0_MOSI/SPI1_MOSI/I2S_DO/I2S_RCLK_O/I2C_SDA/UART_SIG11/SF2_D3/SDIO_DAT1/PWM0_CH3P/PWM0_CH1N/DBI_TypeC_CSn/DISP_QSPI_SDA3/JTAG_TDI (Default available. This IO is shared with the module's internal Flash pin. If the module is customized with internal mounted Flash, this IO is NC.)
42	GND	Ground

Note: Both BOOT and the test point on the back can be used as Bootstrap. If the level is high at the moment of power-on, the module enters flashing/download mode. If the level is low at the moment of power-on, the module boots normally. The module is internally pulled low by default.

## 7 Schematic Diagram

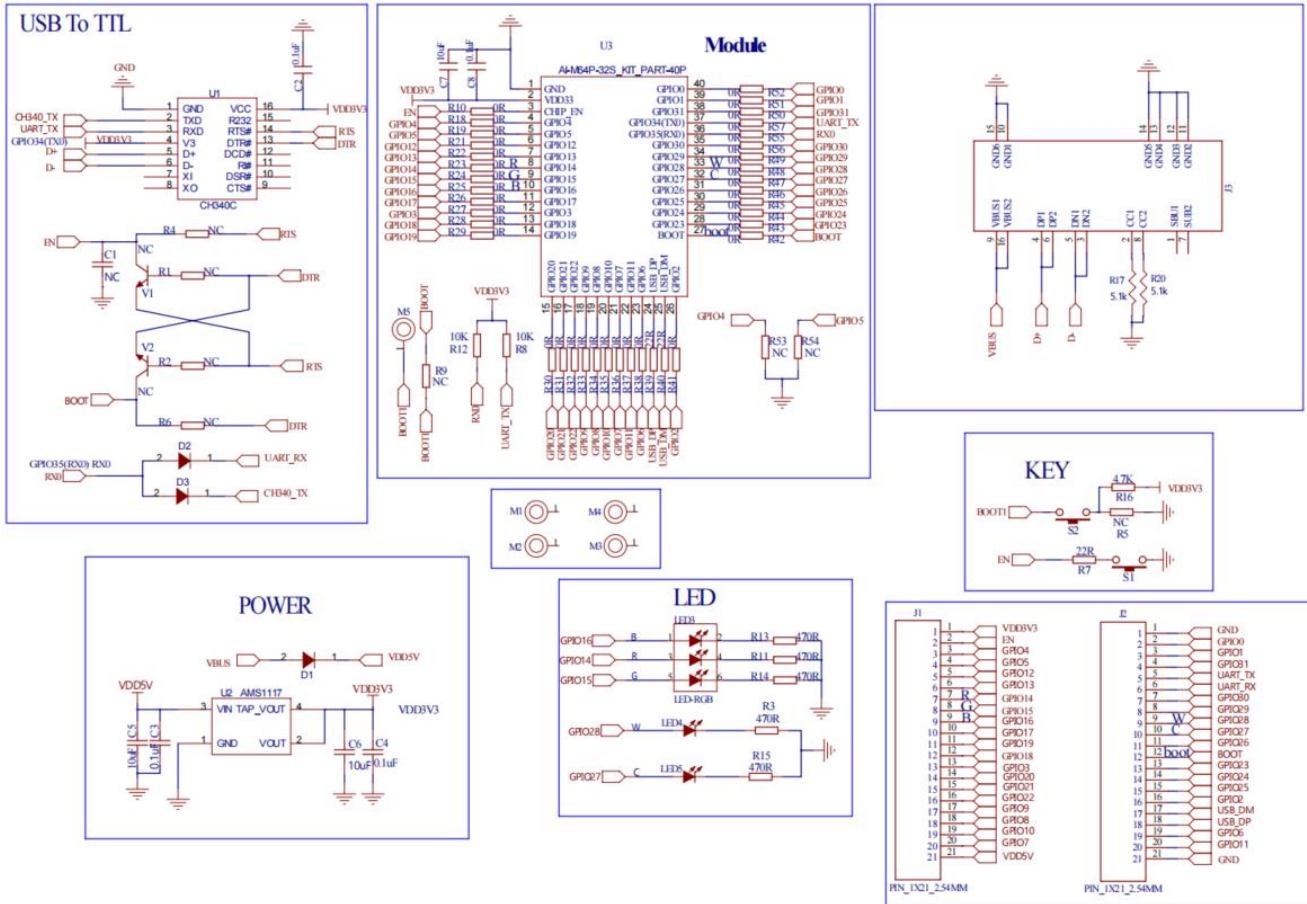

Figure 7 Schematic Diagram

## 8 Packaging Information

**Table 9 Packaging Information**

Packing List	Packaging Method	Quantity per Bag (ESD Bag)	Quantity per Bag (Sealed Bag)
Ai-M64P-32S-Kit	Foam + ESD bag	1pcs	20pcs

## 9 Contact Information

[Official Website](#)

[Official Forum](#)

[Development DOCS](#)

[LinkedIn](#)

[Tmall Store](#)

[Taobao Store](#)

[Alibaba Store](#)

[Technical Support: support@aithinker.com](mailto:support@aithinker.com)

[Domestic Business Cooperation: sales@aithinker.com](mailto:sales@aithinker.com)

[Overseas Business Cooperation: overseas@aithinker.com](mailto:overseas@aithinker.com)

Company Address: Room 403–405, 408–410, Building C, Huafeng Smart Innovation Port, Gushu, Xixiang, Bao'an District, Shenzhen, Guangdong, China

Contact Hotline: 0755-29162996



**WeChat Mini Program**



**WeChat Official Account**

## Disclaimer and Copyright Notice

The information in this document, including referenced URLs, is subject to change without notice.

The document is provided “as is” without warranty of any kind, express or implied, including but not limited to the warranties of merchantability, fitness for a particular purpose, or non-infringement. Furthermore, no warranty is given regarding proposals, specifications, or samples mentioned elsewhere. The publisher bears no responsibility, including for any infringement of patent rights arising from the use of information contained herein. This document does not grant, expressly or impliedly, by estoppel or otherwise, any license to intellectual property rights.

All test data presented herein are obtained from Ai-Thinker laboratories. Actual results may vary slightly.

All trade names, trademarks, and registered trademarks mentioned are the property of their respective owners.

Shenzhen Ai-Thinker Technology Co., Ltd. reserves the final right of interpretation of this document.

## Notice

This manual may be updated due to product version upgrades or other reasons.

Shenzhen Ai-Thinker Technology Co., Ltd. reserves the right to modify the content of this manual without prior notice or announcement.

This manual is intended as a usage guide only. While Shenzhen Ai-Thinker Technology Co., Ltd. strives to provide accurate information, it does not guarantee that the content is entirely free of errors. All statements, information, and recommendations in this manual do not constitute any express or implied warranty.

## Statement

Shenzhen Ai-Thinker Technology Co., Ltd. (hereinafter “Ai-Thinker”) may provide all technical and reliability data (including datasheets), design resources (including reference designs), application or other design advice, web tools, security information, and other resources (collectively referred to as “these Resources”) on an “as is” basis, without warranty of any kind, express or implied, including but not limited to warranties of merchantability, fitness for a particular purpose, or non-infringement of any third-party intellectual property rights. Ai-Thinker specifically disclaims any liability for losses, whether direct or consequential, arising from the application or use of any Ai-Thinker products or circuits.

Ai-Thinker reserves the right to modify the content of this document (including but not limited to specifications and product descriptions) and any related products without prior notice. This document automatically supersedes and replaces all previous versions of the same document number.

These Resources are intended for use by skilled developers designing with Ai-Thinker products. You are solely responsible for: (1) Selecting the appropriate Ai-Thinker products for your application; (2) Designing, validating, and operating your application and product throughout its life cycle; (3) Ensuring your application complies with all applicable standards, laws, and any other functional safety, information security, regulatory, or other requirements.

Ai-Thinker may authorize you to use these Resources solely for developing applications incorporating the Ai-Thinker products described herein. No part of these Resources may be copied, reproduced, or distributed in any form without prior written permission from Ai-Thinker. You are not permitted to use any other intellectual property of Ai-Thinker or any third party. You shall fully indemnify Ai-Thinker and its representatives against any claims, damages, costs, losses, or liabilities arising from your use of these Resources, for which Ai-Thinker assumes no liability.

Ai-Thinker’s products are supplied under Ai-Thinker’s general sales terms and conditions or other applicable terms accompanying the products. The provision of these Resources does not expand or otherwise alter the warranties or warranty disclaimers applicable to the product as delivered.