

Ai-M64P-32S Specification

Version V1.0.0

Copyright ©2026

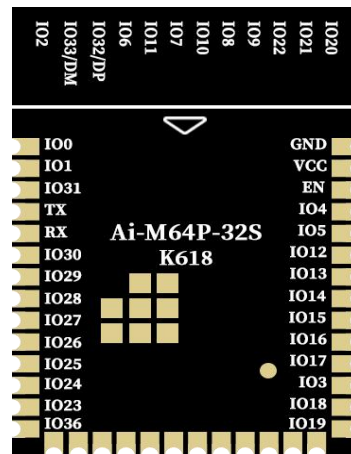

Document Revision History

Version	Date	Description of Changes	Authored by	Approved by
V1.0.0	2026-05-28	First edition	Qiao Rongxin	Guan Ning

Contents

1 Product Overview	5
1.1 Features	6
1.2 Applications	7
2 Main Parameters	8
3 Electrical Characteristics	8
3.1 Recommended Operating Conditions	9
3.2 I/O DC Electrical Characteristics	9
3.3 Electrostatic Discharge	9
3.4 Wi-Fi RF Performance	10
3.5 BLE RF Performance	11
3.6 Power Consumption	12
4 Mechanical Specifications	13
4.1 Module Dimensions	13
4.2 Shield Marking Legend	13
4.3 External Antenna Connector Dimensions	14
5 Pin Definition	15
6 Schematic Diagram	18
7 Antenna Parameters	19
7.1 Antenna Gain and Efficiency	19
7.2 Antenna Pattern Diagram	19
8 Design Guide	20
8.1 Application Circuit	20
8.2 Recommended PCB Footprint Dimensions	21
8.3 Antenna Layout Requirements	21
8.4 Power Supply	22
8.5 GPIO	22
9 Storage Conditions	23
10 Reflow Soldering Profile	23
11 Packaging Information	24
12 Contact Information	24
Disclaimer and Copyright Notice	25
Notice	25
Statement	26

List of Figures

Figure 1	Main Chip Architecture Diagram	5
Figure 2	ESD Protection Symbol	9
Figure 3	Module Dimensions (Unit: mm)	13
Figure 4	Shield Marking Legend	13
Figure 5	External Antenna Connector Dimensions (Unit: mm)	14
Figure 6	Pin Diagram	15
Figure 7	Schematic Diagram	18
Figure 8	Antenna Pattern Diagram	19
Figure 9	Application Circuit	20
Figure 10	Recommended PCB Footprint Dimensions (Unit: mm)	21
Figure 11	Antenna Layout Diagram	21
Figure 12	DC-DC Buck Circuit	22
Figure 13	Level-shifting Circuit	22
Figure 14	Reflow Soldering Profile	23
Figure 15	Tape and Reel Packaging Diagram	24

List of Tables

Table 1	Main Parameter Specification	8
Table 2	Recommended Operating Conditions	9
Table 3	I/O DC Electrical Characteristics	9
Table 4	Wi-Fi RF Performance	10
Table 5	BLE RF Performance	11
Table 6	Power Consumption	12
Table 7	Pin Function Definition	15
Table 8	Antenna Gain and Efficiency	19

1 Product Overview

The Ai-M64P-32S is a standardized wireless module based on the Buffalo Lab BL616CL RF chip, specifically designed for ultra-low power, high-performance, and high-security IoT scenarios. Fully retaining the chip-level RF performance and full-function peripherals, the module undergoes rigorous RF matching and reliability verification with plug-and-play capability, significantly reducing the development barriers and mass-production risks of end products. The product features five core features: strong signal performance, low power consumption, high integration, security and reliability, and ultra-compact package, while also supporting backward compatibility.

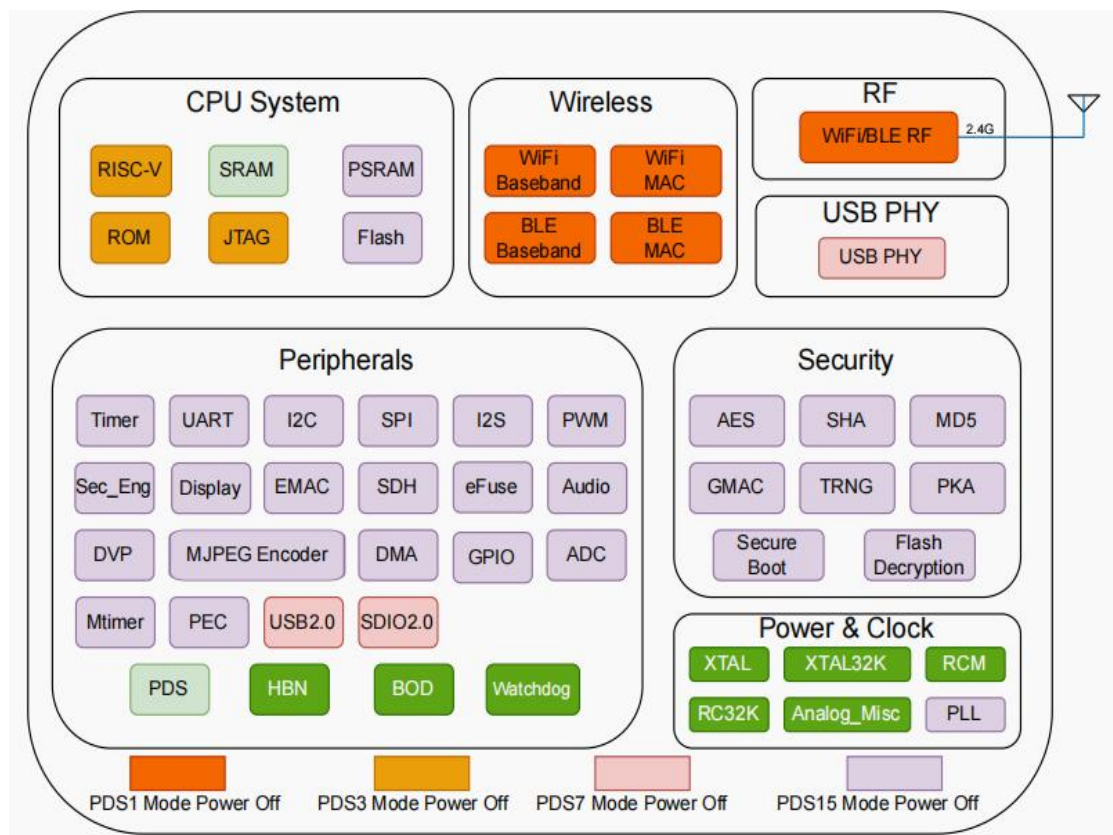

Figure 1 Main Chip Architecture Diagram

1.1 Features

● Wi-Fi 6

- ✧ Supports IEEE 802.11b/g/n/ax, 20MHz bandwidth, 1T1R
- ✧ Fully supports for OFDMA, TWT, LDPC, STBC, Beamformee, and RX diversity, enabling more stable, longer-range, and more power-efficient concurrent connections for multiple devices
- ✧ Receiver sensitivity reaches -99dBm@1Mbps, providing superior wall penetration and long-range coverage compared with similar products
- ✧ Transmit power reaches 23dBm@1Mbps, providing sufficient link margin and no disconnection in weak network environments

● BLE 5.3 Long Range and Low Latency

- ✧ Supports BLE 5.3 with multiple data rates: 2Mbps, 1Mbps, 500kbps, and 125kbps
- ✧ Receiver sensitivity reaches -99dBm@125kbps
- ✧ Supports multi-connection, extended advertising, AOI/AOD, compatible with gateways and sensor nodes

● Wi-Fi/BLE Coexistence

- ✧ Built-in coexistence engine at chip level. No external switch is required, and dual-mode TDD operation is supported without interference
- ✧ Supports BLE-assisted Wi-Fi fast connection, with over 50% faster provisioning speed

● High Computing Performance and Large Memory

- ✧ 32-bit RISC-V CPU, up to 320MHz, with FPU and DSP, supporting edge computing
- ✧ Built-in 388KB SRAM, 224KB OCRAM, 160KB WRAM, 4KB HBN RAM, optional 2/4/8MB Flash and 4/8MB PSRAM

● Full-Function Interfaces, One Module Replacing Multiple Chips

- ✧ Integrated USB2.0 HS, EMAC 10/100M, DVP camera, DBI display, MJPEG codec
- ✧ Rich peripherals: 3*UART, 2*I2C, 2*SPI, 1*I2S, 1*PWM (4 channels), 1*16-bit GPADC (12 channels), and 1*Touch interface

● Industrial-grade Low Power Consumption and Security

- ✧ Supports PDS (Power Down Sleep) and HBN (Hibernate) modes. Sleep current is at the μ A level, helping extend battery life
- ✧ Secure boot, firmware encrypt and sign, TrustZone, full hardware encryption with AES/SHA/PKA/TRNG, protecting against cracking and tampering

● High Reliability and Easy Mass Production

- ✧ Normal operating temperature: -40–85°C (customizable to -40–105°C)
- ✧ Pre-certified RF parameters shorten the certification cycle, plug-and-play

Note: For features not listed in this document, please refer to the BL616CL chip datasheet.

1.2 Applications

- Audio and Video Multimedia
- Internet of Things (IoT)
- Mobile Devices
- Smart Home
- Central Control Devices

2 Main Parameters

Table 1 Main Parameter Specification

Model	Ai-M64P-32S
Package	SMD-40
Dimensions	25.5*18.0*3.1 (mm)
Antenna Type	On-board antenna/I-PEX connector antenna
Frequency Range	2400–2483.5MHz
Operating Temperature	-40–85°C
Storage Conditions	-40–125°C, <90% RH
Power Supply Range	Supply voltage: 2.97–3.63V, typical value 3.3V; supply current >500mA
Available I/Os	37 (default)
UART Baud Rate	115200bps (default)
Wi-Fi Security	WPS/WEP/WPA/WPA2/WPA3
Flash	4MB (default), up to 16MB

3 Electrical Characteristics

3.1 Recommended Operating Conditions

Table 2 Recommended Operating Conditions

Symbol	Parameter	Min	Typ	Max	Unit
VCC	Supply Voltage	2.97	3.3	3.63	V
I	Supply Current	500	-	-	mA

3.2 I/O DC Electrical Characteristics

Table 3 I/O DC Electrical Characteristics

Symbol	Parameter	Min	Typ	Max	Unit
VIH	High-level Input Voltage	2	-	-	V
VIL	Low-level Input Voltage	-	-	0.8	V
VOH	High-level Output Voltage	-	0.9*VCC	-	V
VOL	Low-level Output Voltage	-	0.1*VCC	-	V

3.3 Electrostatic Discharge

The M64P-32S is an ESD-sensitive device and requires special precautions during handling.



Figure 2 ESD Protection Symbol

3.4 Wi-Fi RF Performance

Table 4 Wi-Fi RF Performance

Description	Typ			Unit
Frequency Range	2400–2483.5			MHz
Output Power				
Mode	Min	Typ	Max	Unit
802.11b, 11Mbps	-	19	23	dBm
802.11g, 54Mbps	-	18	20	dBm
802.11n, HT20 (MCS7)	-	18	19	dBm
802.11ax, HE20 (MCS9)	-	16	17	dBm
Receiver Sensitivity				
Mode	Min	Typ	Max	Unit
802.11b, 1Mbps	-99	-	-	dBm
802.11b, 11Mbps	-90	-	-	dBm
802.11g, 6Mbps	-93	-	-	dBm
802.11g, 54Mbps	-78	-	-	dBm
802.11n, HT20 (MCS7)	-76	-	-	dBm
802.11ax, HE20 (MCS9)	-69	-	-	dBm

3.5 BLE RF Performance

Table 5 BLE RF Performance

Description	Typ			Unit
Frequency Range	2400–2483.5			MHz
Output Power				
Data Rate Mode	Min	Typ	Max	Unit
1Mbps	-	10	15	dBm
2Mbps	-	10	15	dBm
Receiver Sensitivity				
Data Rate Mode	Min	Typ	Max	Unit
1Mbps Sensitivity @ 30.8% PER	-99	-	-	dBm
2Mbps Sensitivity @ 30.8% PER	-97	-	-	dBm

3.6 Power Consumption

The following power consumption data are measured based on a 3.3V power supply and an ambient temperature of 25°C.

- The POUT power for all transmit modes is measured at the antenna interface.
- All transmission data are measured at 100% duty cycle in continuous transmit mode.

Table 6 Power Consumption

Mode	Min	Avg	Max	Unit
TX 802.11b, 11Mbps, POUT = +23dBm	-	435	-	mA
TX 802.11g, 54Mbps, POUT = +20dBm	-	352	-	mA
TX 802.11n, MCS7, POUT = +19dBm	-	338	-	mA
TX 802.11ax, MCS9, POUT = +17dBm	-	290	-	mA
RX 802.11b, Packet Length 1500 bytes	-	84.5	-	mA
RX 802.11g, Packet Length 1500 bytes	-	84.5	-	mA
RX 802.11n, Packet Length 1500 bytes	-	84.5	-	mA
RX 802.11ax, Packet Length 1500 bytes	-	84.5	-	mA
PDS (Tickless 3), Wi-Fi Disconnected	-	45	-	μA
PDS (Tickless 3), Wi-Fi Connected	-	256	-	μA
PDS (Tickless 10), Wi-Fi Disconnected	-	45	-	μA
PDS (Tickless 10), Wi-Fi Connected	-	90	-	μA
HBN Mode	-	5	-	μA

4 Mechanical Specifications

4.1 Module Dimensions

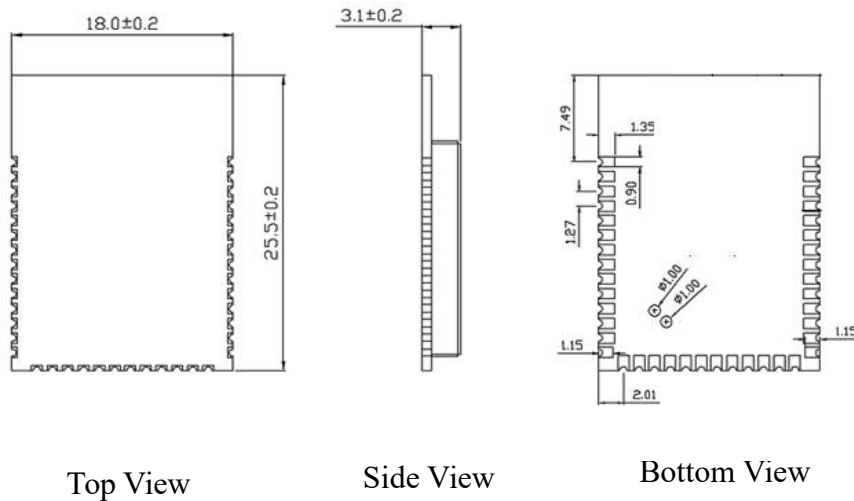

Figure 3 Module Dimensions (Unit: mm)

4.2 Shield Marking Legend

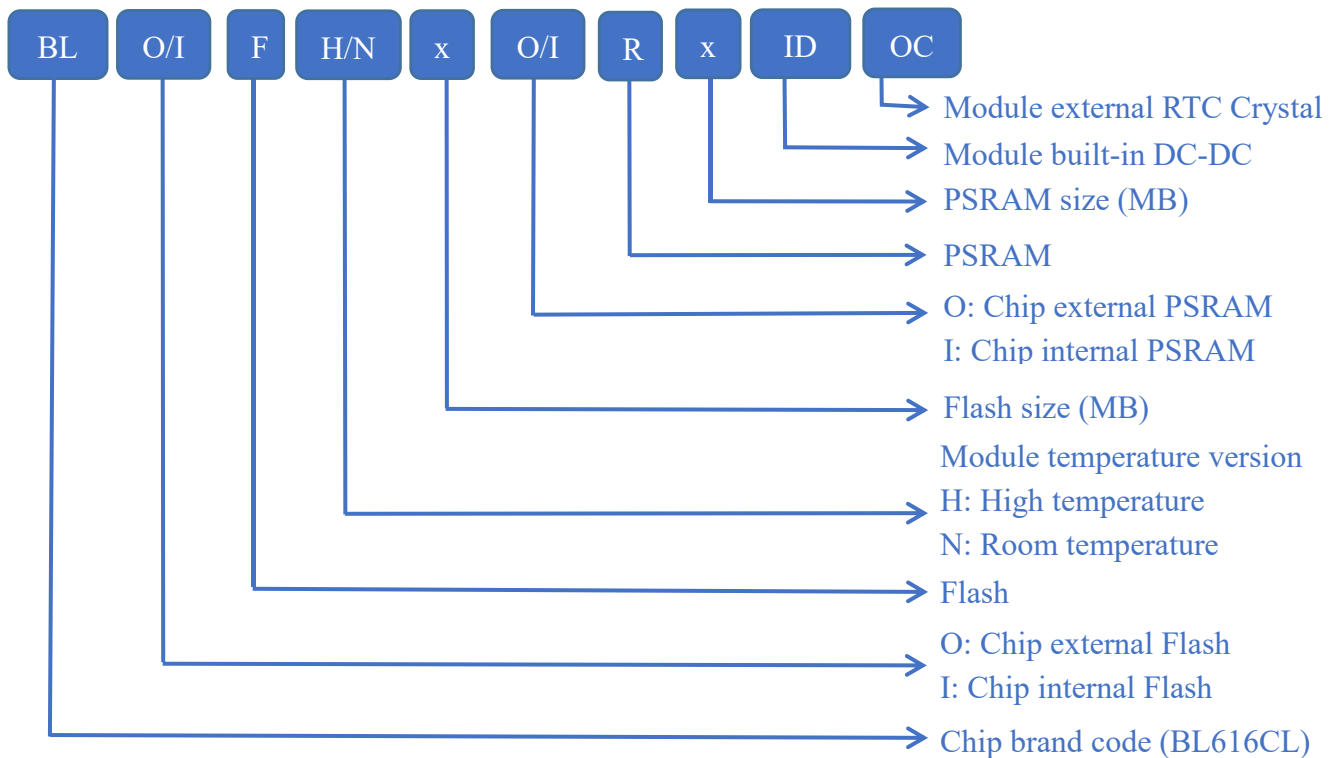

Figure 4 Shield Marking Legend

4.3 External Antenna Connector Dimensions

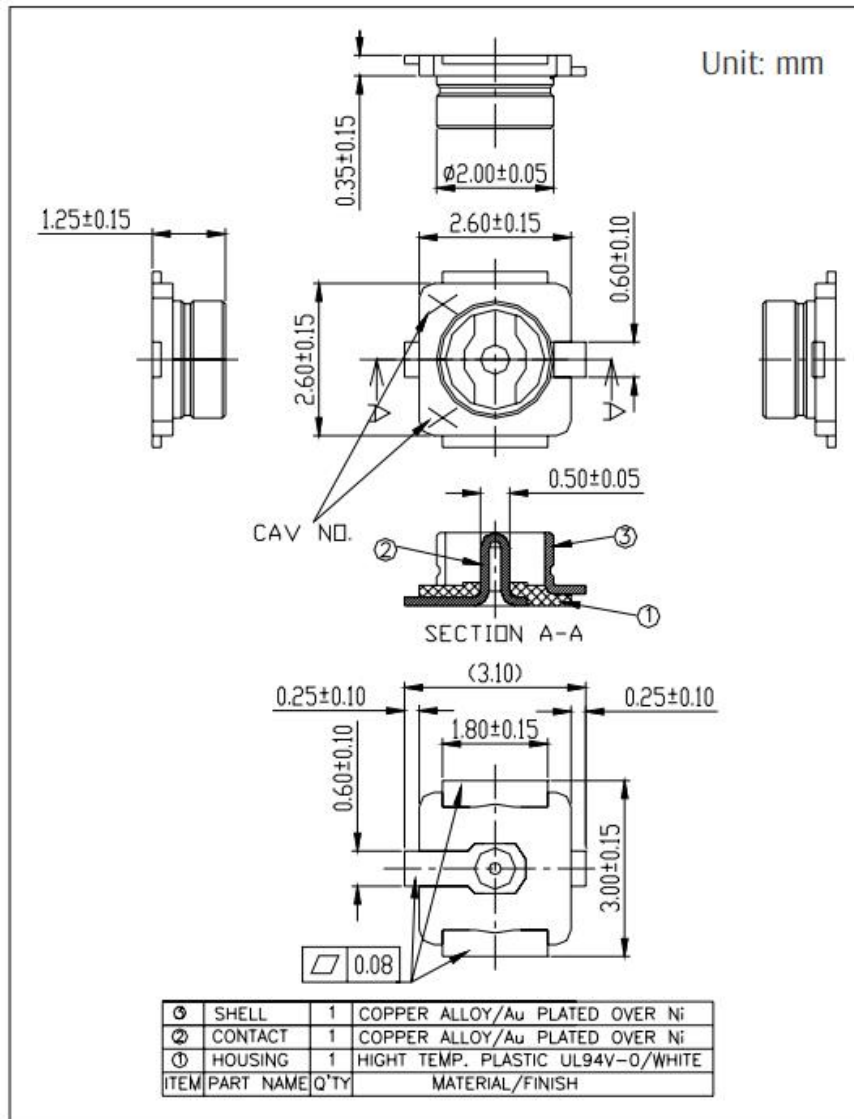
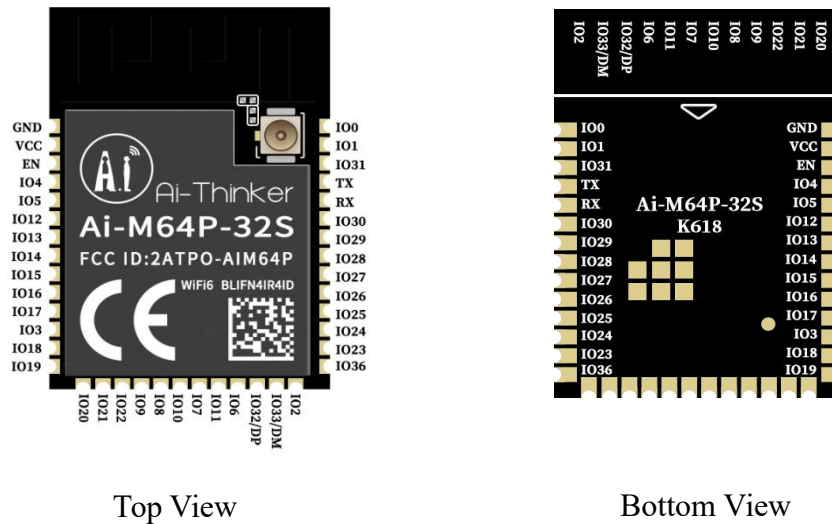

Figure 5 External Antenna Connector Dimensions (Unit: mm)

5 Pin Definition

The Ai-M64P-32S module exposes a total of 40 pins, as shown in the pin diagram. The pin function definition table provides the detailed interface specifications.



Top View

Bottom View

Figure 6 Pin Diagram

Table 7 Pin Function Definition

No.	Name	Function
1	GND	Ground
2	VCC	3.3V power supply; supply current recommended >500mA
3	EN	Default chip enable pin, active-high
4	IO4	GPIO4/SPI0_SS/SPI1_SS/I2S_BCLK/I2C_SCL/PWM0/ADC_CH4 (Default available. This IO is shared with the module's internal 32.768kHz crystal input pin. If the module is customized with an internal mounted 32.768kHz crystal, this IO is NC.)
5	IO5	GPIO5/SPI0_SCLK/SPI1_SCLK/I2S_FS/I2C_SDA/PWM0/ADC_CH5 (Default available. This IO is shared with the module's internal 32.768kHz crystal output pin. If the module is customized with an internal mounted 32.768kHz crystal, this IO is NC.)
6	IO12	GPIO12/SPI0_SS/SPI1_SS/I2S_BCLK/I2C_SCL/PWM0/ADC_CH8
7	IO13	GPIO13/SPI0_SCLK/SPI1_SCLK/I2S_FS/I2C_SDA/PWM0/ADC_CH9
8	IO14	GPIO14/SPI0_MISO/SPI1_MISO/I2S_DI/I2S_RCLK_O/I2C_SCL/PWM 0

9	IO15	GPIO15/SPI0_MOSI/SPI1_MOSI/I2S_DO/I2S_RCLK_O/I2C_SDA/PWM0
10	IO16	GPIO16/SPI0_SS/SPI1_SS/I2S_BCLK/I2C_SCL/PWM0
11	IO17	GPIO17/SPI0_SCLK/SPI1_SCLK/I2S_FS/I2C_SDA/PWM0
12	IO3	GPIO3/SPI0_MOSI/SPI1_MOSI/I2S_DO/I2S_RCLK_O/I2C_SDA/PWM0/ADC_CH3 (Default unavailable. This IO is internally connected to the module DC-DC for low-power use. If low power is not required and this IO needs to be used, please contact Ai-Thinker for customization.)
13	IO18	GPIO18/SPI0_MISO/SPI1_MISO/I2S_DI/I2S_RCLK_O/I2C_SCL/PWM0
14	IO19	GPIO19/SPI0_MOSI/SPI1_MOSI/I2S_DO/I2S_RCLK_O/I2C_SDA/PWM0
15	IO20	GPIO20/SPI0_SS/SPI1_SS/I2S_BCLK/I2C_SCL/PWM0
16	IO21	GPIO21/SPI0_SCLK/SPI1_SCLK/I2S_FS/I2C_SDA/PWM0
17	IO22	GPIO22/SPI0_MISO/SPI1_MISO/I2S_DI/I2S_RCLK_O/I2C_SCL/PWM0
18	IO9	GPIO9/SPI0_SCLK/SPI1_SCLK/I2S_FS/I2C_SDA/PWM0 (Default available. This IO is shared with the module's internal Flash pin. If the module is customized with internal mounted Flash, this IO is NC.)
19	IO8	GPIO8/SPI0_SS/SPI1_SS/I2S_BCLK/I2C_SCL/PWM0. (Default available. This IO is shared with the module's internal Flash pin. If the module is customized with internal mounted Flash, this IO is NC.)
20	IO10	GPIO10/SPI0_MISO/SPI1_MISO/I2S_DI/I2S_RCLK_O/I2C_SCL/PWM0 (Default available. This IO is shared with the module's internal Flash pin. If the module is customized with internal mounted Flash, this IO is NC.)
21	IO7	GPIO7/SPI0_MOSI/SPI1_MOSI/I2S_DO/I2S_RCLK_O/I2C_SDA/PWM0/ADC_CH7 (Default available. This IO is shared with the module's internal Flash pin. If the module is customized with internal mounted Flash, this IO is NC.)
22	IO11	GPIO11/SPI0_MOSI/SPI1_MOSI/I2S_DO/I2S_RCLK_O/I2C_SDA/PWM0 (Default available. This IO is shared with the module's internal Flash pin. If the module is customized with internal mounted Flash, this IO is NC.)
23	IO6	GPIO6/SPI0_MISO/SPI1_MISO/I2S_DI/I2S_RCLK_O/I2C_SCL/PWM0/ADC_CH6 (Default available. This IO is shared with the module's internal Flash pin.

		If the module is customized with internal mounted Flash, this IO is NC.)
24	IO32/DP	USB_DP/GPIO32/SPI0_SS/SPI1_SS/I2S_BCLK/I2C_SCL/PWM0/ADC_CH10
25	IO33/DM	USB_DM/GPIO33/SPI0_SCLK/SPI1_SCLK/I2S_FS/I2C_SDA/PWM0/ADC_CH11
26	IO2	GPIO2/SPI0_MISO/SPI1_MISO/I2S_DI/I2S_RCLK_O/I2C_SCL/PWM0/ADC_CH2 (Default unavailable. This IO is internally connected to the module DC-DC for low-power use. If low power is not required and this IO needs to be used, please contact Ai-Thinker for customization.)
27	IO36	Disabled by default; please contact Ai-Thinker if required. GPIO36/SPI0_SS/SPI1_SS/I2S_BCLK/I2C_SCL/PWM0
28	IO23	GPIO23/SPI0_MOSI/SPI1_MOSI/I2S_DO/I2S_RCLK_O/I2C_SDA/PWM0
29	IO24	GPIO24/SPI0_SS/SPI1_SS/I2S_BCLK/I2C_SCL/PWM0
30	IO25	GPIO25/SPI0_SCLK/SPI1_SCLK/I2S_FS/I2C_SDA/PWM0
31	IO26	GPIO26/SPI0_MISO/SPI1_MISO/I2S_DI/I2S_RCLK_O/I2C_SCL/PWM0
32	IO27	GPIO27/SPI0_MOSI/SPI1_MOSI/I2S_DO/I2S_RCLK_O/I2C_SDA/PWM0
33	IO28	GPIO28/SPI0_SS/SPI1_SS/I2S_BCLK/I2C_SCL/PWM0
34	IO29	GPIO29/SPI0_SCLK/SPI1_SCLK/I2S_FS/I2C_SDA/PWM0
35	IO30	GPIO30/SPI0_MISO/SPI1_MISO/I2S_DI/I2S_RCLK_O/I2C_SCL/PWM0
36	RX	GPIO35/SPI0_MOSI/SPI1_MOSI/I2S_DO/I2S_RCLK_O/I2C_SDA/PWM0
37	TX	GPIO34/SPI0_MISO/SPI1_MISO/I2S_DI/I2S_RCLK_O/I2C_SCL/PWM0
38	IO31	GPIO31/SPI0_MOSI/SPI1_MOSI/I2S_DO/I2S_RCLK_O/I2C_SDA/PWM0
39	IO1	GPIO1/SPI0_SCLK/SPI1_SCLK/I2S_FS/I2C_SDA/PWM0/ADC_CH1
40	IO0	GPIO0/SPI0_SS/SPI1_SS/I2S_BCLK/I2C_SCL/PWM0/ADC_CH0

Note:

1. IO36 and the test point on the module's bottom side can both be used as Bootstrap pins. If it is high at the moment of power-on, the module enters flashing mode. If it is low at the moment of power-on, the module boots normally. The module is internally pulled low by default.

6 Schematic Diagram

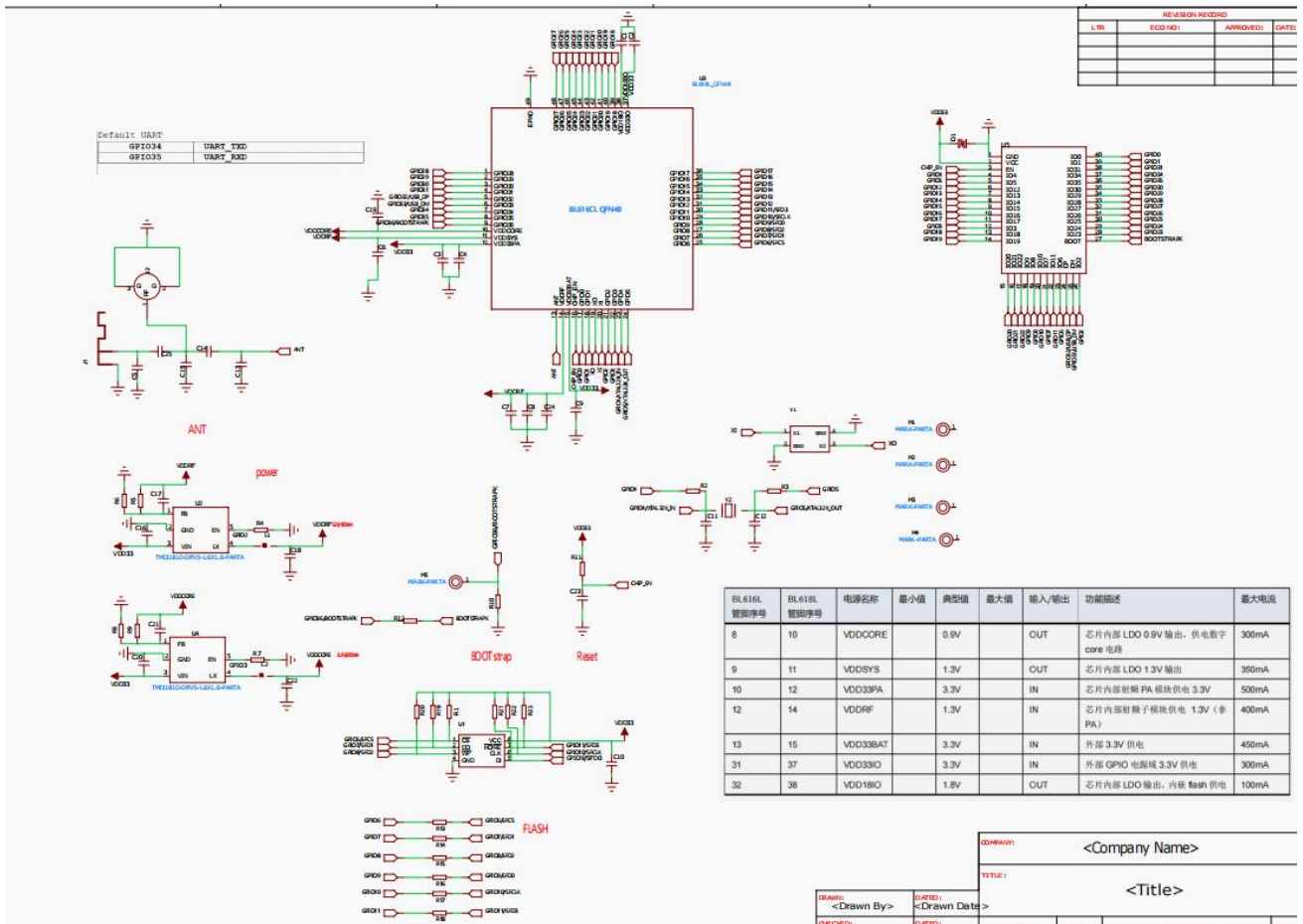

Figure 7 Schematic Diagram

7 Antenna Parameters

7.1 Antenna Gain and Efficiency

Table 8 Antenna Gain and Efficiency

No.	1	2	3	4	5	6	7	8	9	10	11
Frequency (MHz)	2400	2410	2420	2430	2440	2450	2460	2470	2480	2490	2500
Gain (dBi)	0.99	1.21	1.39	1.31	1.55	1.47	1.54	1.60	1.69	1.35	1.77
Efficiency (%)	51.24	53.39	56.41	57.07	57.38	58.33	57.25	55.55	55.26	55.35	57.00

7.2 Antenna Pattern Diagram

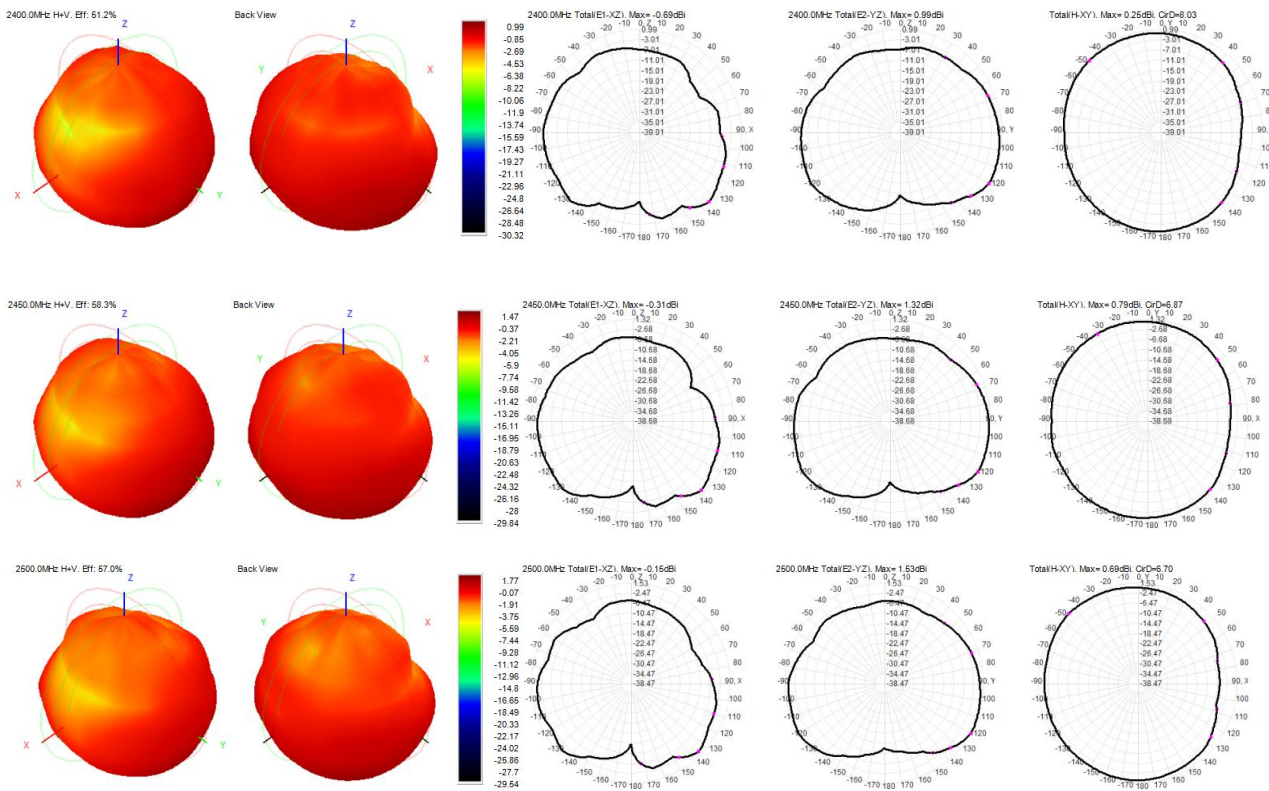

Figure 8 Antenna Pattern Diagram

8 Design Guide

8.1 Application Circuit

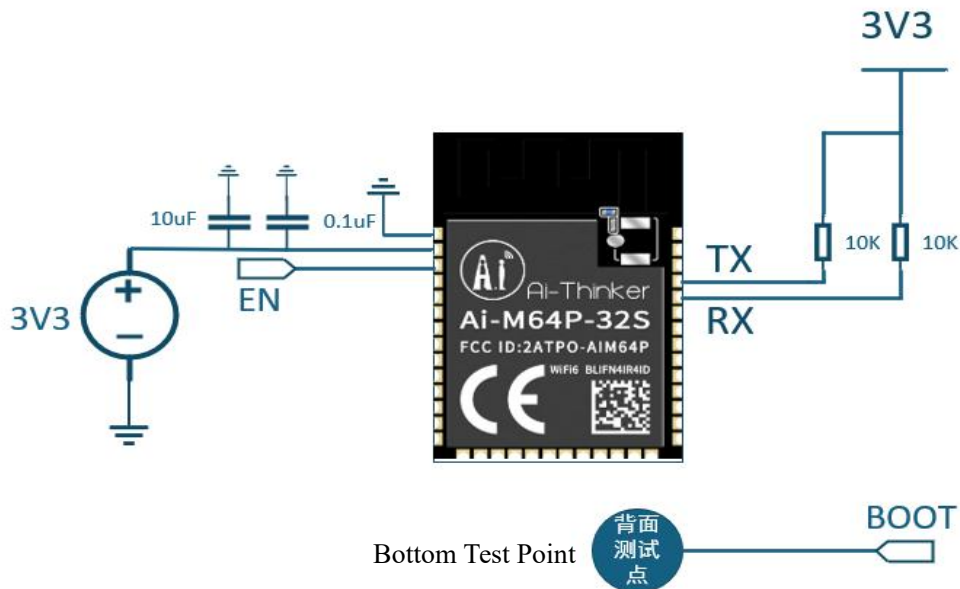

Figure 9 Application Circuit

- VCC supply voltage: 2.97–3.63V. The external power supply output current is recommended to be above 500mA.
- IO36 and the test point on the bottom side can both be used as Bootstrap pins. If the level is high at the moment of power-on, the module enters flashing mode. If the level is low at the moment of power-on, the module boots normally. The module is internally pulled low by default.
- IO36 is NC by default; contact Ai-Thinker if this pin needs to be externally led out.

8.2 Recommended PCB Footprint Dimensions

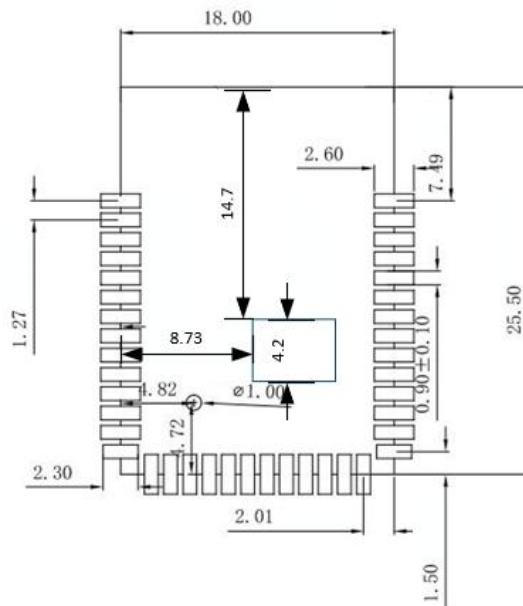

Figure 10 Recommended PCB Footprint Dimensions (Unit: mm)

8.3 Antenna Layout Requirements

- For the installation position on the mainboard, the following 2 options are recommended.
Option 1: Place the module at the mainboard edge, with the antenna area extending beyond it.
Option 2: Place the module at the mainboard edge, with a clearance cutout at the antenna position.
- To ensure optimal antenna performance, metal components should be kept away from the antenna area, and the antenna should be placed as far as possible from high-frequency devices.

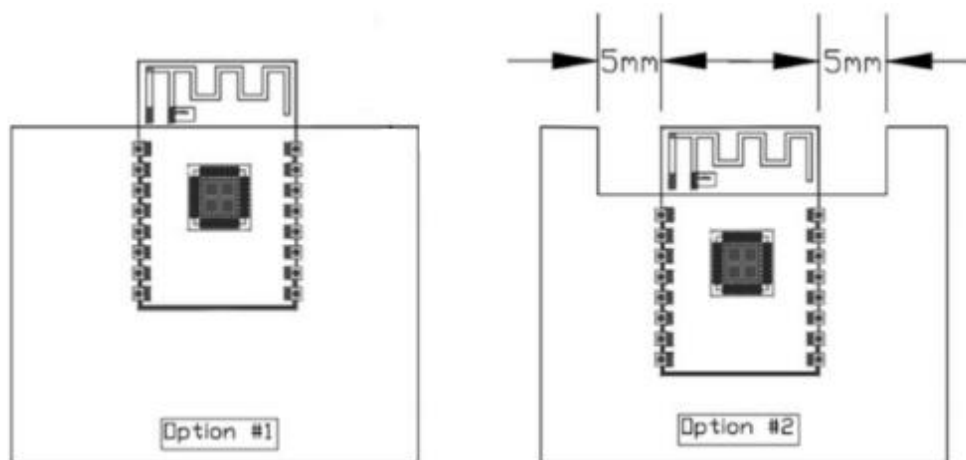

Figure 11 Antenna Layout Diagram

8.4 Power Supply

- VCC is recommended as 3.3V, with a peak current above 500mA.
- An LDO is recommended for power supply; if using DC-DC, the ripple should be controlled within 30mV.
- For the DC-DC power supply circuit, it is recommended to reserve space for dynamic response capacitors to optimize output ripple under large load transients.
- It is recommended to add ESD protection devices to the power interface.

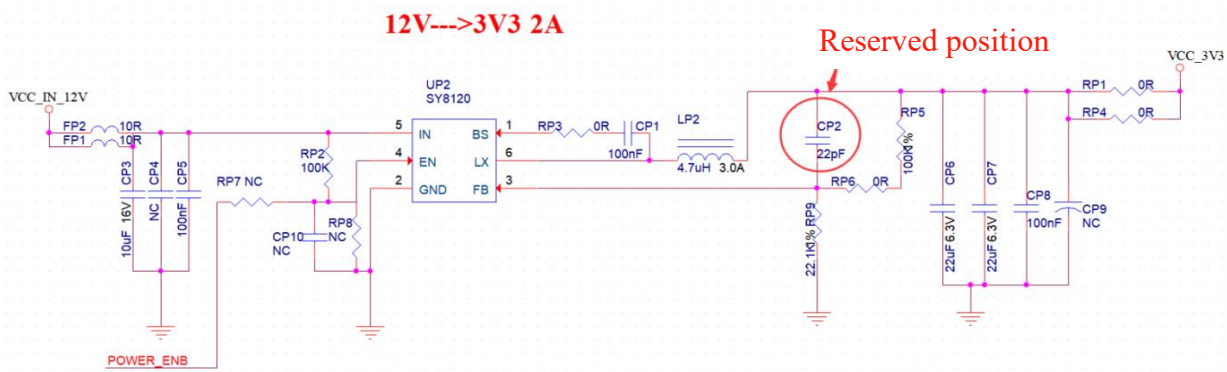

Figure 12 DC-DC Buck Circuit

8.5 GPIO

- Some I/O pins are exposed on the module periphery. To use these I/O pins, it is recommended to connect a 10-100Ω resistor in series with each I/O pin. This helps suppress overshoot, stabilize signal levels, and benefits both EMI and ESD protection.
- The pull-up or pull-down configuration for special I/O pins must follow the guidelines in the specification, as it affects the module’s boot configuration.
- The module’s I/O pins operate at 3.3V. If the I/O voltage level of the main controller and the module do not match, a level-shifting circuit must be added.
- If an I/O pin is directly connected to a peripheral interface or pin headers, it is recommended to reserve space for an ESD protection device near the connector on the I/O trace.

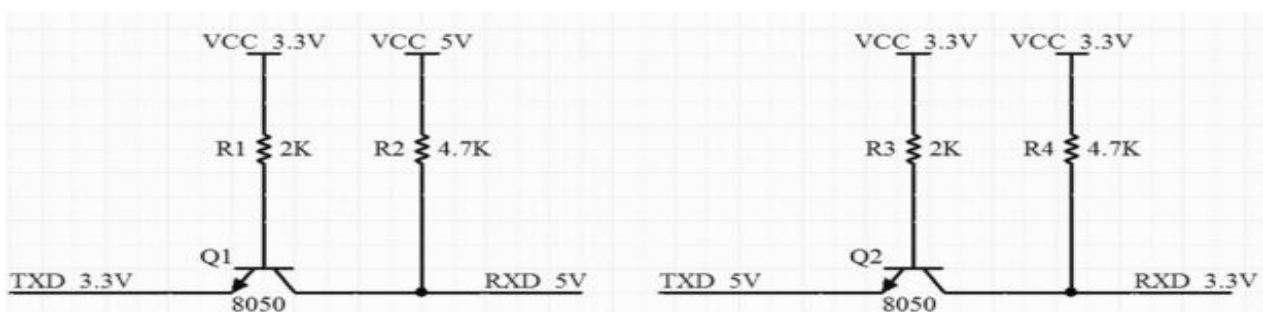

Figure 13 Level-shifting Circuit

9 Storage Conditions

Products sealed in moisture barrier bags should be stored in a non-condensing atmosphere at $< 40^{\circ}\text{C}$ and $< 90\% \text{ RH}$.

The moisture sensitivity level (MSL) of the module is level 3.

The module must be used within 168 hours after vacuum bag removal under conditions of $25\pm 5^{\circ}\text{C}$ and $60\% \text{ RH}$. Otherwise, the module requires baking before being returned to production.

10 Reflow Soldering Profile

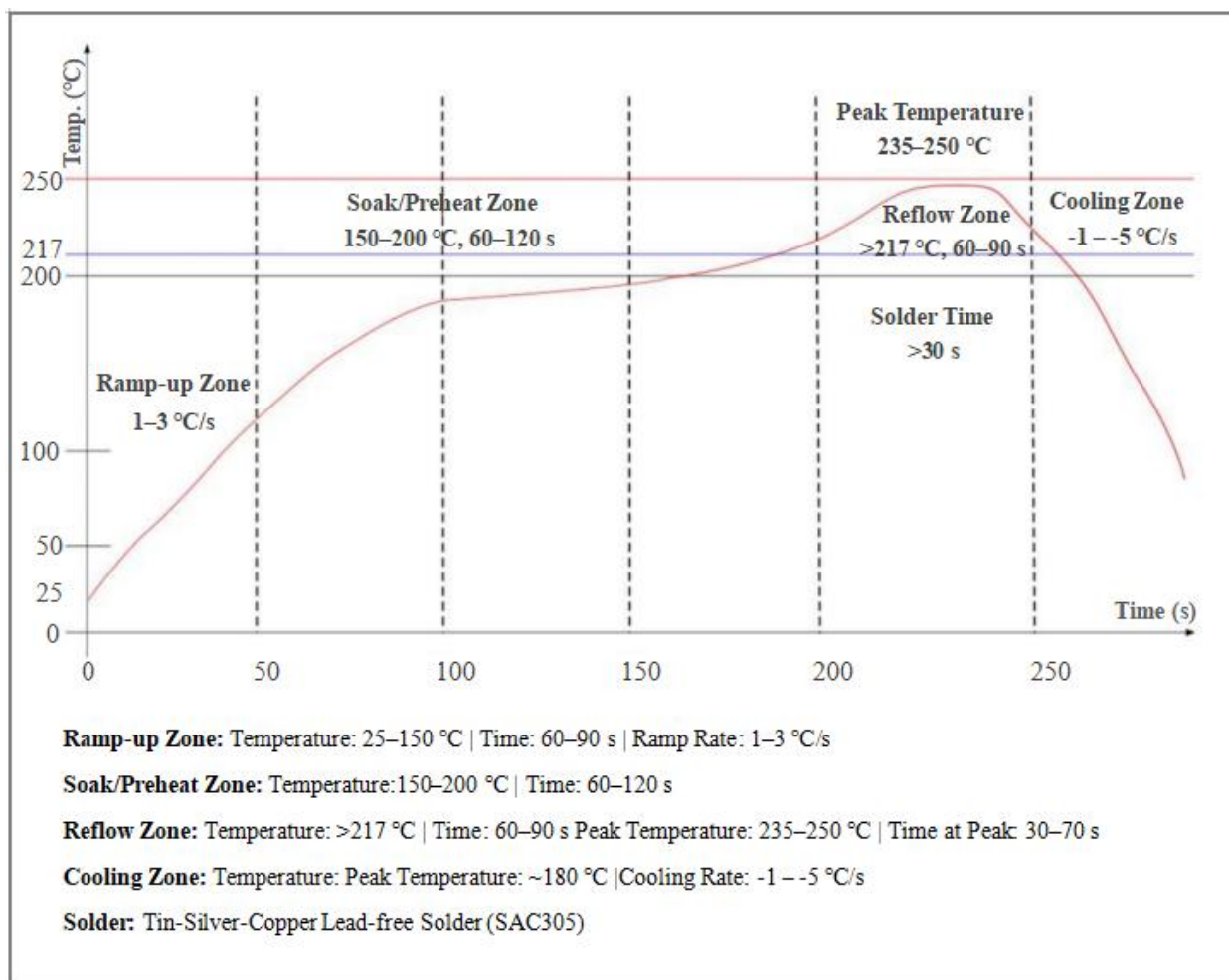

Figure 14 Reflow Soldering Profile

11 Packaging Information

The Ai-M64P-32S module is packaged in tape and reel, 800 pcs/reel.



Figure 15 Tape and Reel Packaging Diagram

12 Contact Information

[Official Website](#)

[Official Forum](#)

[Development DOCS](#)

[LinkedIn](#)

[Tmall Store](#)

[Taobao Store](#)

[Alibaba Store](#)

[Technical Support: support@aithinker.com](mailto:support@aithinker.com)

[Domestic Business Cooperation: sales@aithinker.com](mailto:sales@aithinker.com)

[Oversea Business Cooperation: overseas@aithinker.com](mailto:overseas@aithinker.com)

Company Address: Room 403–405, 408–410, Building C, Huafeng Smart Innovation Port, Gushu, Xixiang, Bao'an District, Shenzhen, Guangdong, China

Contact Hotline: 0755-29162996



WeChat Mini Program



WeChat Official Account

Disclaimer and Copyright Notice

The information in this document, including referenced URLs, is subject to change without notice.

The document is provided “as is” without warranty of any kind, express or implied, including but not limited to the warranties of merchantability, fitness for a particular purpose, or non-infringement. Furthermore, no warranty is given regarding proposals, specifications, or samples mentioned elsewhere. The publisher bears no responsibility, including for any infringement of patent rights arising from the use of information contained herein. This document does not grant, expressly or impliedly, by estoppel or otherwise, any license to intellectual property rights.

All test data presented herein are obtained from Ai-Thinker laboratories. Actual results may vary slightly.

All trade names, trademarks, and registered trademarks mentioned are the property of their respective owners.

Shenzhen Ai-Thinker Technology Co., Ltd. reserves the final right of interpretation of this document.

Notice

This manual may be updated due to product version upgrades or other reasons.

Shenzhen Ai-Thinker Technology Co., Ltd. reserves the right to modify the content of this manual without prior notice or announcement.

This manual is intended as a usage guide only. While Shenzhen Ai-Thinker Technology Co., Ltd. strives to provide accurate information, it does not guarantee that the content is entirely free of errors. All statements, information, and recommendations in this manual do not constitute any express or implied warranty.

Statement

Shenzhen Ai-Thinker Technology Co., Ltd. (hereinafter “Ai-Thinker”) may provide all technical and reliability data (including datasheets), design resources (including reference designs), application or other design advice, web tools, security information, and other resources (collectively referred to as “these Resources”) on an “as is” basis, without warranty of any kind, express or implied, including but not limited to warranties of merchantability, fitness for a particular purpose, or non-infringement of any third-party intellectual property rights. Ai-Thinker specifically disclaims any liability for losses, whether direct or consequential, arising from the application or use of any Ai-Thinker products or circuits.

Ai-Thinker reserves the right to modify the content of this document (including but not limited to specifications and product descriptions) and any related products without prior notice. This document automatically supersedes and replaces all previous versions of the same document number.

These Resources are intended for use by skilled developers designing with Ai-Thinker products. You are solely responsible for: (1) Selecting the appropriate Ai-Thinker products for your application; (2) Designing, validating, and operating your application and product throughout its life cycle; (3) Ensuring your application complies with all applicable standards, laws, and any other functional safety, information security, regulatory, or other requirements.

Ai-Thinker may authorize you to use these Resources solely for developing applications incorporating the Ai-Thinker products described herein. No part of these Resources may be copied, reproduced, or distributed in any form without prior written permission from Ai-Thinker. You are not permitted to use any other intellectual property of Ai-Thinker or any third party. You shall fully indemnify Ai-Thinker and its representatives against any claims, damages, costs, losses, or liabilities arising from your use of these Resources, for which Ai-Thinker assumes no liability.

Ai-Thinker’s products are supplied under Ai-Thinker’s general sales terms and conditions or other applicable terms accompanying the products. The provision of these Resources does not expand or otherwise alter the warranties or warranty disclaimers applicable to the product as delivered.